

# E-EDR Series Closed-Loop Driver Instruction Manual

## I. Product Features

- Operating voltage: DC input voltage 24VDC to 80VDC, recommended operating voltage 36V/48V
- Max. continuous output current 8.0A, max. peak current 13A
- Advanced variable current technology and inverter technology are adopted to effectively reduce the heat of motor and driver
- The number of pulses per revolution can be set by a subdividing dip switch
- Functions of protection against over-voltage, under-voltage, over-current and out-of-tolerance error are available
- Maximum pulse frequency of control command is 500KHz (factory default setting is 200KHz)
- Input interface level of pulse, direction and enable signals is 4.5 to 28V compatible
- Performance: smooth speed, low overshoot, small tracking error, less heat of motor and driver

### ■ Areas of application

Suitable for various small and medium-sized automation equipment and instruments, such as: screw locking machine, wire stripping machine, wire winding machine, terminal machine, laser machine, spray painting machine, small and medium-sized engraving machine, electronic processing equipment, automatic gripping equipment, special CNC machine tools, packaging equipment and robots. Particularly effective in equipment where low noise and high speed are expected by the user.

## II. Electrical, Mechanical and Environmental Indicators

### ■ Electrical indicators

Parameters	E-EDR Series			
	Minimum value	Typical value	Maximum value	Unit
Continuous output current	0.5	—	13	A
Power supply voltage (DC)	24	36/48	80	Vdc
Logic input current	6	10	16	mA
Logic input voltage	4.5	5	28	Vdc
Pulse frequency	0	200	500	kHz
Insulation resistance	100	—	—	MΩ

## Usage environment and parameters

Cooling method		Natural cooling or forced air cooling
Usage environment	Conditions	Keep it away from other heat-generating equipment, and avoid using it in places exposed to dust, oil mist, corrosive gas, excessive humidity and strong vibration, or places with combustible gases and conductive dust.
	Temperature	-5°C to +45°C
	Humidity	40 to 90%RH
	Vibration	10 to 55Hz / 0.15mm
Storage temperature		-20°C to +65°C
Operating altitude		≤1000m
Weight		Approx. 1.4KG

## Precautions for heat dissipation

The ambient temperature for reliable operation of the driver usually ranges from -5°C to 45°C. The operating temperature is 65°C or less for the driver and 70°C or less for the motor. If necessary, install a fan near the driver to forcibly dissipate heat so that the driver operates within a reliable operating temperature range.

## III. Driver Interface and Wiring

### Control port

Green 8-pin 3.81mm pitch terminal is adopted

Pin number	Signal	Function	Description
1	PUL+	Positive pulse input side	Compatible with 4.5V to 28V level signals
2	PUL-	Negative pulse input side	
3	DIR+	Positive direction input side	
4	DIR-	Negative direction input side	
5	ENA+	Positive enable input side	
6	ENA-	Negative enable input side	
7	ALM+	Positive alarm signal output side	Open collector OC output, maximum pull-up level 24V, maximum output current 100mA
8	ALM-	Negative alarm signal output side	

### Power supply port

Green 3-pin 3.81mm pitch terminal with screw is adopted (Pay attention to the power supply polarity. Never reversely connect the positive and negative poles!!!!)

Pin number	Signal	Function Description
1	+VDC	Positive power supply input side, input voltage is 24 to 80Vdc
2	GND	Negative power supply input side
3	NC	No signal



### Power supply port

Green 6-pin 3.81mm pitch terminal with screw is adopted (Pay attention to the power supply polarity. Never reversely connect the positive and negative poles!!!!)

Pin number	Signal	Function Description
1	EB+	Encoder signal B+ input
2	EB-	Encoder signal B- input
3	EA+	Encoder signal A+ input
4	EA-	Encoder signal A- input
5	VCC	Driver +5V output, supplying power to the encoder
6	EGND	Driver GND output, supplying power to the encoder

### LED status indication

Green LED is the power indicator, which will stay ON when the driver is powered on and turn OFF when the driver is powered off. Red LED is the fault indicator, which will flash in a cycle of 5 seconds when there is a fault and stay OFF when the fault is cleared by the user. Red LED will flash at a frequency of 2Hz, ON for 200ms and OFF for 300ms. The number of flashes of the red LED in 5 seconds represents different fault messages, with the specific relationship shown in the following table.

SN	Number of Flashes	Red Indicator Flashing Waveform	Fault Description
1	1		Over-current fault ( $I_{peak} \geq 25A$ )
2	2		Over-voltage fault ( $V_{dc} \geq 90V$ )
3	5		Tracking error out-of-tolerance fault

When a driver failure occurs, the driver will shut down and show the corresponding fault code. The user needs to turn the power off, then on again.

### Control signal interface circuit

The driver signal input interface can connect differential signal input, common anode signal single-end input and common cathode signal single-end input, built-in high-speed opto-isolated coupler; the output is the triode open collector OC output, with interface connection as follows.

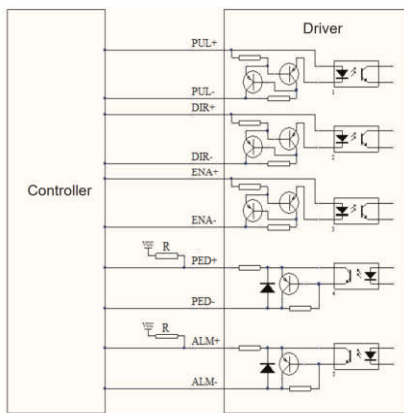

Figure 1 Differential connection of input signal

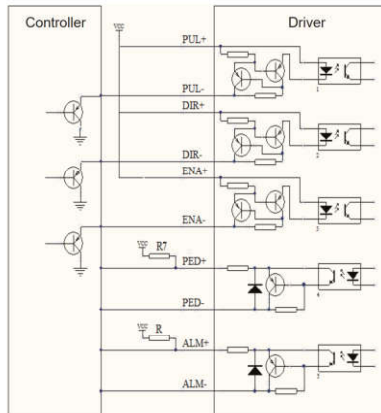

Figure 2 Single-end common anode connection of input signal

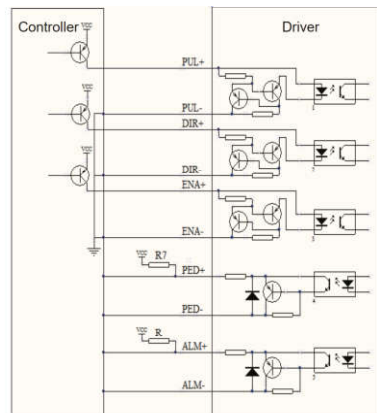

Figure 3 Single-end common cathode connection of input signal

Note: The signal input interface voltage range shown is 4.5 to 28Vdc, and there is no need to connect current limiting resistors in series, regardless of single-end connection or differential connection. If the external pull-up voltage of the output interface is up to 28Vdc and the maximum output current is 100mA, choose a suitable pull-up resistance according to the external pull-up voltage and the basic parameter value. Choose 2K for the pull-up resistance if the external pull-up voltage is 24Vdc, and 1K if it is 12Vdc. In case of driving the relay or motor brake coil, please consult our application engineer.

## Sequence chart of control signals

In order to avoid some misoperations and deviations, PUL-, DIR- and ENA- should abide by some rules, as shown in the following figure.

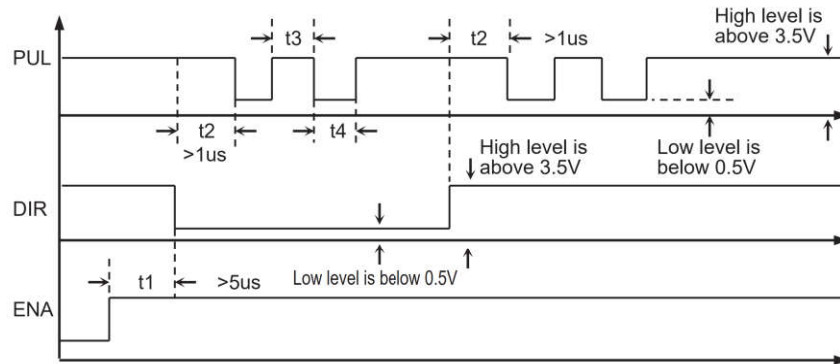

Figure 4 Sequence chart of control signals

### Notes:

- 1) t1: ENA (enable signal) should be ahead of DIR by at least  $5\mu\text{s}$ , which is determined as high level. It is generally recommended that it is left unused.
- 2) t2: DIR should be ahead of the falling edge of PUL by at least  $1\mu\text{s}$ , which is determined as high or low level.
- 3) t3: pulse width is at least not less than  $1.5\mu\text{s}$ .
- 4) t4: low level width is not less than  $1.5\mu\text{s}$ .

## Wiring requirements

- 1) In order to protect the driver from interference, it is recommended that shielded cable line be used for the control signal, and the shield layer be shorted to the ground. Except for special requirements, the shield line of the control signal cable is grounded at one end: the host end of the shield line is grounded, and the driver end of the shield line is left unused. Within the same machine, grounding is only allowed to be made at the same point. In case the grounding line is not real, there may be serious interference. At this time the shield layer is not connected. If the conditions allow, the use of thermal grounding technology is most effective for shielding.
- 2) Pulse and direction signal lines and motor lines are not allowed to bundle together side by side. It is best to separate them at least 10cm or more, otherwise motor noise is likely to interfere with the pulse direction signal, resulting in inaccurate motor positioning, system instability and other failures.
- 3) In case of one power supply for more than one driver, parallel connection should be taken at the power supply, not allowing chain connection first to one and then to another.
- 4) It is strictly forbidden to unplug the driver terminals with power on. There is still a large current flowing through the coil when the motor stops with power on, so unplugging the terminals will lead to a huge instantaneous inductive electric potential, which will burn out the driver.
- 5) It is strictly forbidden to connect tin-plated lead wire end to the terminal, otherwise the terminal may be damaged by overheating due to the large contact resistance.
- 6) The wire end should not be exposed outside the terminal to prevent accidental short circuit and damage to the driver.

#### IV. Dip switch setting

The servo drive uses an 8-bit dip switch to set the subdivision accuracy (electronic gear ratio), the initial direction of motor rotation, self-test and function mode selection. Detailed description is as follows.

Pulse/rev	S1	S2	S3	S4	IO/RPM
Default	On	On	On	On	10
800	Off	On	On	On	20
1600	On	Off	On	On	30
3200	Off	Off	On	On	40
6400	On	On	Off	On	50
12800	Off	On	Off	On	60
25600	On	Off	Off	On	80
51200	Off	Off	Off	On	100
1000	On	On	On	Off	120
2000	Off	On	On	Off	150
4000	On	Off	On	Off	200
5000	Off	Off	On	Off	250
8000	On	On	Off	Off	300
10000	Off	On	Off	Off	350
20000	On	Off	Off	Off	450
40000	Off	Off	Off	Off	600

SW5: Motor DIR      OFF=CCW, ON=CW

SW6: Motor selection      OFF=closed, ON=open

Model sel	SW7	SW8
IO internal pulse	ON	ON
Self-test check	OFF	ON
Double pulse	ON	OFF
Pulse + direction	OFF	OFF

## V. Protection Functions

### 1) Over-voltage protection

When the input voltage is higher than 90Vdc, the driver will stop working. At this time, the fault must be removed and the power must be turned on again to reset.

### 2) Under-voltage protection

When the input voltage is lower than 15Vdc, the driver will stop working. At this time, the fault must be removed and the power must be turned on again to reset.

### 3) Over-current protection

When over-current occurs, the driver will stop working. At this time, the fault must be removed and the power must be turned on again to reset.

### 4) Tracking error out-of-tolerance

The TS808D driver will stop working when the tracking error is out of tolerance. At this time, the fault must be removed and the power must be turned on again to reset.

△ **Note** : Since the driver does not have the protection function for reverse polarity of power supply, please confirm the correct wiring polarity of power supply again before turning the power on. Reverse polarity will lead to burnout of the fuse in the driver!

## VI. Common Problems

### Common problems in the application and countermeasures

Symptom	Possible Problem	Solution
Motor does not turn	Power light does not light up	Check the power supply circuit, and properly supply power
	Motor shaft braking force is large	Weak pulse signal, signal current increase to 7-16mA
	Subdivision setting is too small	Select the proper subdivision setting
	Driver is protected	Turn the power on again
	Enable signal is low	This signal is pulled up to high level or not connected
	No response to control signal	Power is not turned on
	Motor cable breakage	Check and connect properly
	Voltage is too high or too low	Check power supply
	Motor or driver is damaged	Replace motor or driver
Inaccurate positioning	Signal is disturbed	Eliminate interference
	Shield ground is not connected or not properly connected	Ground reliably
	Motor cable breakage	Check and connect properly
	Subdivision setting error	Set the subdivision properly
Motor stalls when accelerating	Acceleration time is too short	Acceleration time is too long
	Motor torque is too small	Select a high torque motor
	Voltage is low	Increase voltage properly

## ■ FAQ about the driver

### 1) What are the advantages of subdividing servo driver?

- The step uniformity is improved by reducing the step angle of each step, the control accuracy can be improved.
- Motor vibration can be greatly reduced. Low-frequency oscillation is an inherent characteristic of a stepper motor, and subdivision is the best way to eliminate it.
- It can effectively reduce the torque pulsation and increase the output torque.  
These advantages above are generally recognized by users and bring them benefits, so it is recommended that you'd better use the subdividing driver.

### 2) Why does my motor only run towards one direction?

- Maybe the direction signal is too weak, or the wiring polarity is wrong, or the signal voltage is too high, leading to burnout of the direction current limiting resistor.
- Pulse mode mismatch. If the signal is pulse/direction, the driver must be set to this mode.