

# MISUMI

## Economical Temperature Controller

This manual describes the function, performance and usage of the product. Please note the following before using this product:

- Sufficient knowledge about electrical system is required to use this product.
- Understand the contents of this manual before using this product.
- Pay attention to and observe the prohibited items of this product when using it.
- The examples given in the manual and other technical materials are for the user's reference only.
- Confirm that this product complies with the relevant specifications and usage when it is used in combination with other products.

### A1 Contents index

A1	Contents Index	B2	Description of Main Menu Display
A2	Usage Warnings	B3	Manufacturer Parameters
	Precautions	B4	Description of Device Parameters
A3	Electrical Specifications	B5	Other Information
A4	Product Selection	C1	Function of Error Display
A5	Table of Outline Dimensions and Hole Dimensions	C2	Diagram of Wiring Examples
B1	Functional Description of Operation Panel	C3	Instrument Simple Troubleshooting and Maintenance

### A2 Usage Warnings



#### Warning

- ① Do not touch the AC power terminals after the controller is powered on to avoid electric shock
- ② Confirm that the power supply voltage complies with the controller's specifications before the controller is powered on, otherwise the controller may be damaged
- ③ Never disassemble, modify or repair this product or touch any of its internal components
- ④ The contacts will sometimes melt and burn if the output relay exceeds the expected service life
- ⑤ Tighten the terminal screws with a torque of 0.74—0.90 N.m, otherwise loose screws may cause fire
- ⑥ To avoid the damage or failure of the instrument, select the proper fuse to protect the power line and input/output line from current impact
- ⑦ To prevent fire, explosion, or damage to the instrument, it is forbidden to use the product in places exposed to flammable and explosive gases or where steam is discharged
- ⑧ This product has been strictly inspected before leaving the factory. If there is a quality problem, the company guarantees it for one year. The responsibility it bears is limited to the product itself, and it is not responsible for any other joint and several liabilities. Damage caused by self-disassembly or improper use is not covered by the warranty.

### A2 Precautions

- ① Do not block the ventilation hole of the product and allow the heat to dissipate
- ② Do not install the controller in a place exposed to high frequency interference, corrosive gas, high temperature and high humidity, freezing and condensation, liquid or oil and gas splashing
- ③ Allow as much space as possible between the controller and devices that generate a high frequency or surge
- ④ Confirm that the connection between the wiring and the device terminal is correct
- ⑤ Use the product under the correct rated load and power supply
- ⑥ Do not clean this product using paint thinner or similar chemicals
- ⑦ Read the information provided in the catalog and manual carefully before connecting the control output unit
- ⑧ Stop using this product immediately if its housing is broken

### A3 Electrical Specifications

Rated voltage	100V-240VAC, 50Hz
Power consumption	≤5VA
Working environment	Ambient temperature: 0°C-50°C Relative humidity: 35%-85% RH (with no condensation)
Storage temperature	-25°C-65°C (with no freezing or condensation)
Resolution	1°C, 0.1°C (adjustable)
Wiring method	Wiring terminal
Measurement accuracy	±0.5%FS
Memory protection	Non-volatile memory
Installation environment	Installation category II, pollution degree 2
Relay output	Relay contact AC220V/DC30V, 5A
Logic level output	When ON: DC12V; When OFF: DC0.5V or less; Maximum current: 30mA, load resistance ≥1K

### A4 Product Selection

- ① Main output 1: Model: C-MTCTRS (relay + solid state relay)  
2: Model: C-MTCTRST (relay + solid state relay+RS485)

\* Refer to B4 for the switching mode of relay and solid state output.  
The default factory setting is relay output.  
\* C-MTCTRS has no communication interface

- ② Input signal

Name	K	J	R	S	B	E	N	T	PT	CU	O.K
Code	ℓ	ℓ	r	S	b	E	n	ℓ	Pℓ	ℓ	o.ℓ

- ③ Alarm output 1

Value of AL1T	Meaning
0	No alarm, AL1 menus will not be displayed by default
1	Absolute value upper limit alarm
2	Deviation upper limit alarm
3	Absolute value lower limit alarm
4	Deviation lower limit alarm
5	Out-of-band (out-of-range) alarm
6	In-band (in-range) alarm
P-1	Absolute value upper limit alarm with power-on hold function
P-2	Deviation upper limit alarm with power-on hold function
P-3	Absolute value lower limit alarm with power-on hold function
P-4	Deviation lower limit alarm with power-on hold function

### A5 Table of Outline Dimensions and Hole Dimensions

- C-MTCTRS
- C-MTCTRST (including RS485 communication)

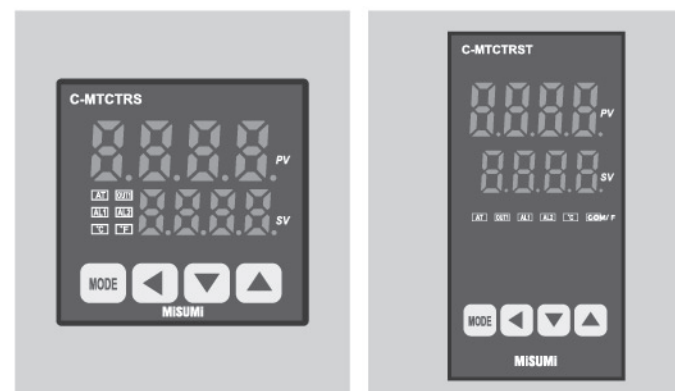

Unit: mm

Model	Panel size	Housing size L x W x H	Hole size
C-MTCTRS	48×48	45×45×75	45×45
C-MTCTRST	48×96	45×92×75	45×92

### B1 Functional description of operation panel

- Name of each part

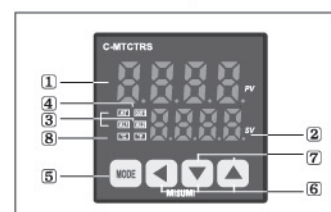

- ① Display (red) of current value (PV)  
The current measured value (PV) is displayed in the operation mode, and the internal parameter name is displayed in the setting mode.
- ② Display (green) of set value (SV)  
The set value (SV) of the control target is displayed in the operation mode, and the current set value of the parameter is displayed in the setting mode.
- ③ Control/alarm output indicators  
— Auto-tuning indicator: the AT light flashes in a cycle of 1 second when auto-tuning is performed. Hold the MODE key for three seconds and find 1. Then the AT light on the thermostat is on. Just wait for it to go off. Do not turn off the power or change the parameters during the setting process.  
\* In case of cycle/phase control of SSR drive output, it will turn ON when MV is over 3.0%.  
— AL1: lights up when Alarm1/Alarm2 output is ON.
- ④ OUT: Lights up when the Main Control Output is ON.
- ⑤ MODE key: used to enter the parameter group setting, return to the operation mode, switch the parameter group, and save the set value.
- ⑥ Direction keys: used to enter the setting value change mode or move the digits, and change the value up/down.
- ⑦ Function keys: Press the [▼]+[▲] keys simultaneously for 3 seconds to start the [DI-K] digital input key function (run/stop, alarm clear, auto-tuning) setting.
- ⑧ Temperature unit indicator (°C/°F): Displays the current temperature unit.

### B2 Description of Main Menu Display

Description of main menu display (press and hold the MODE key for 3 seconds to enter the main menu interface)

1. User parameters

In the normal measurement and control state, press the MODE key once to enter the user parameter setting. Press it again to enter the next user parameter setting until all parameters are set.

Code	Designation	Parameter meaning	Description	Setting range	Default	Display condition
SV	SV	Temperature setting	Temperature set value	SLL-SLH	150°C	The manual function is turned off. The percentage of control power is displayed when the manual function is turned on
ST	ST	Set the operating time of the instrument	This parameter exists only when the timing function is enabled (ET=1,2,3). See the timing section for details. When the unit is minutes, the last digit of the parameter setting displays a decimal point, indicating minutes.	0-9999s/m	60	Cod = 40 Ton = 1000 ET != 0

2. Engineer parameters

Press and hold the MODE key for 3 seconds to enter the engineer parameter setting state. To exit, press MODE for 1 second. To set the next parameter, press MODE once.

Engineer parameters are described in the table below

Code	Designation	Parameter meaning	Description	Setting range	Default	Display condition
AL1	AL1	1st alarm	There are 12 alarm modes, which are determined by AL1T.	-1999-9999	30	AL1!=0
SC	SC	Displayed value allowance	Make displayed value = Pb value + internal measured value;	-50-50	0	1
P	P	Proportional band	If it is 0, it is position control, and the I and D menus will not be displayed at this time, but the HY menu will be displayed.	0-9999	30	1
OH	OH	Position control bottom hysteresis	Hysteresis of the main control when the main control is 2-position control (P=0), operates when PV < SV-OHL	0-200	2	P=0
OHH	OHH	Position control top hysteresis	Hysteresis of the main control when the main control is 2-position control (P=0), and OFF when PV < SV+OHL	0-200	0	P=0
I	I	Integral time constant	If it is set to zero, the integral control action is canceled	0-9999	240	P != 0
D	D	Derivative time constant	If it is set to zero, the derivative action is canceled	0-9999	60	P != 0
T	T	Control cycle	Action cycle of main control	0-100	20	P != 0
AR	AR	Integral limiter	Used as integral limiter	0-100	100	P != 0
ATU	ATU	Auto-tuning switch	OFF: close; ON: open	OFF/ON	OFF	P != 0
Lck	Lck	Parameter lock	0: Unlocked 1: User parameters locked 2: All parameters locked	0-2	0	1

### B3 Manufacturer Parameters

Press and hold the MODE key and the left shift key simultaneously until Cod(  $\underline{Cod}$  ) is displayed. In this state, enter 0010 and then press the MODE key to access the following menu. After setting, press the MODE key again to return to Cod(  $\underline{Cod}$  ). The parameters at this level only apply to instrument engineers or manufacturers, and common users should not use them.

Code	Designation	Parameter meaning	Description	Setting range	Default	Display condition
RLt	AL1T	1st alarm Alarm mode selection	See the Alarm Mode Description Table	0-5,P1-P5	2	1
RHl	AH1	1st alarm relay hysteresis	Alarm relay hysteresis	0-200	1	1
RH	AH	Overheat shutdown deviation	Turn off the output in case of PV>SV+AH	0-999	30	
FP	FP	Proportional band adjustment	Move the proportional band down by FP degrees, effectively reducing or eliminating the overshoot of the first temperature rise	0-100	5	1
SLL	SLL	Minimum set value setting	The minimum set value that can be set by the user	Full scale	0	1
SLH	SLH	Maximum set value setting	The maximum set value that can be set by the user	Full scale	1370	1
PL	PL	Minimum power limit	Limit the minimum output power that the instrument can output	0-30%	0%	1
PH	PH	Maximum power limit	OUT=0: The maximum output power of the instrument after the measured temperature enters the proportional band OUT=1,2: The maximum output power of the instrument	30-100%	100%	1
dLY	DLY	Minimum time interval for main control action during cooling	Prevent the compressor from starting and stopping frequently, which leads to compressor damage or overload protection circuit action	0-200s	0	1
dP	dP	PT100, CU50, decimal point position for linear input	The decimal point is only valid for linear input (SV, SV), and invalid for thermocouple and thermal resistance signals	0-3	0	1
df	DF	Filter coefficient	The larger the SL6, the better the filtering effect and the more stable the display	0-250	200	
Rddr	Addr	Communication address	Instrument communication address	1-250	1	Con=100
bPS	bps	Communication baud rate	Set the communication rate, i.e. the baud rate	300-38400	19200	Con=100
Et	ET	Timing function enabled	0: No timing 1: Main control output timing. When the AL1 reaches the timing temperature, the timing starts. After the timing ends, turn off the control output, and wait for the operation; the 4 decimal points of the SP digital tube flash every half a second, indicating that the timing ends and the output is turned off. Turn on AL2 according to the SL setting. 2: One-shot timing. When the AL1 reaches the timing temperature, the timing starts. After the timing ends, the control output is not turned off, but only serves as a reminder. Turn on AL2 according to the SL setting. After the AL2 timing ends, the timing restarts after the AL1 reaches the temperature, and the cycle repeats. 3: Cycle timing. When the AL1 reaches the timing temperature, the timing starts. After the timing ends, the control output is not turned off, but only serves as a reminder. Turn on AL2 according to the SL setting. After the AL2 timing ends, the timing restarts after the AL1 reaches the temperature, and the cycle repeats. 4: The main control starts to output after delaying the ST time when the timing startup is completed.	0, 1, 2, 3, 4	0	Ton=1000
EtE	TIE	Timing time unit	0: seconds 1: minutes	0.1	0	Ton=1000
RLt	ALT	Deviation temperature triggered by timer	In case of ET=1,2,3, the instrument starts to count down when the temperature reaches the SP-AL1 value. If the value of AL1 is big, the countdown can be started as soon as the instrument is powered on.	0-9999°C	1°C	Ton=1000
BL	BL	The time for the 2nd alarm relay to operate when the timing ends	0: The 2nd alarm relay does not operate when the timing ends 250: The 2nd alarm relay always operates when the timing ends 1-249: The time for the timing alarm relay to operate (seconds) when the timing ends	0-250s	5s	Ton=1000

### 计时说明:

After the timing function is turned on when the set temperature is reached, press the left shift key and the Down key simultaneously to check the timing status. The SV position displays the timing status. When the timing is not started, the set time is displayed. When the unit is minutes, the last digit displays the decimal point. During the process of timing, the countdown is displayed. When the unit is minutes, the last decimal point flashes every half a second, and 0000 is displayed when the timing ends. In the non-menu status, long press the left shift key and the Up key to reset the timing and restart the state (whether the timing is underway or ends). If the timing parameters are modified, the timing state is also reset. In case of Timing Status 2, the heating starts after the timing ends.

### B4 Description of Setting Parameters

Press and hold the MODE key and the left shift key simultaneously until Cod(  $\underline{Cod}$  ) is displayed. In this state, modify the state of Cod(  $\underline{Cod}$  ) =0020 by Up/Down keys.

Code	Designation	Meaning	Other Description	Range	Default Value
Sn	SN	Select the sensor input signal	Different input models need to match different input resistances.	K, J, R, S, B, E, N, T, PT, Cu, O,K,	K
unit	Unit	Unit selection	°C: Celsius; °F: Fahrenheit	°C, °F	°C
out	OUT	Output* mode	RLY: switch relay output SSR: DC12V output	RLY	RLY
dir	Dir	Control direction	HOT: heating control, that is, reverse control; COL: cooling control, that is, forward control; H-C: Simultaneous control of heating and cooling  HOT/COL mode output control is OUT1 H-C mode. OUT1 is heating control output. OUT2 is cooling control output.	Description of HOT, COL, H-C: For COL and H-C control modes, only RLY mode is applicable	HOT
Et	Tt	Temperature tracking amount	Make the displayed temperature approach the set value within the range of the set value±Tt	0-10	6
FRL	FAC	Overheat display limit	0-Off function For other values, after exceeding the set value, the exceeded portion is displayed proportionally Display value = SV+ (PV-SV)/FAC	0-100	0

Note: \* Factory setting is RLY for both relay and SSR output modes. To select the SSR mode, refer to parameter COD = 0060, item 3 on the next page, and change the parameter SrrL value from 0 to 1.

COD=0040: Enter factory parameter 4

- CTON = 1000: You can directly modify the SU value through the Up/Down keys. The upper row does not display SU
- TON = 0000: Alarm 1 is an excitation alarm  
0001: Alarm 1 is a non-excitation alarm  
= 1000: ET timing function is available
- CON = 0001: Can be manually opened and closed output (i.e. sv shows stop) Tap shift key to open  
  
0100: Communication function is available  
1000: You can turn on the self-adaptive function

COD=0060: Enter factory parameter 5

- LBAT output fault monitoring time  
LBAB output fault monitoring width  
LBAB heating output monitoring width with the unit same as PV value.  
If the PV measured temperature change is less than LBAB after the full cycle heating output or the full cycle off output and the duration is LBAT time, the heating fault will be prompted.  
If the change is greater than LBAB, the heating fault will not be prompted.  
SV=EER1 indicates a heating fault.
- RLRS solid state and relay selection output  
SrrL Select whether the heating type is relay or solid state signal output  
=0 Relay heating =1 Solid state heating

Hold down the MODE key and the mobile key, and 1168 appears to restore the factory settings

### B5 Other Information

- Comparison of anti-disturbance performance

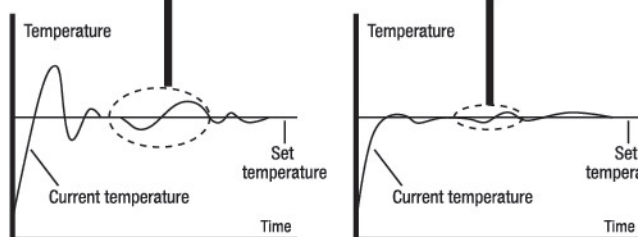
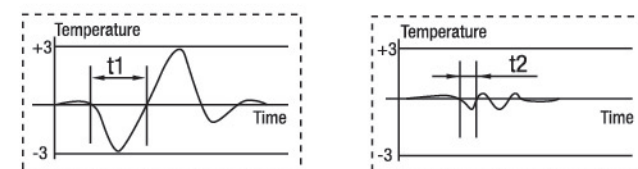

- Comparison of first overshoot

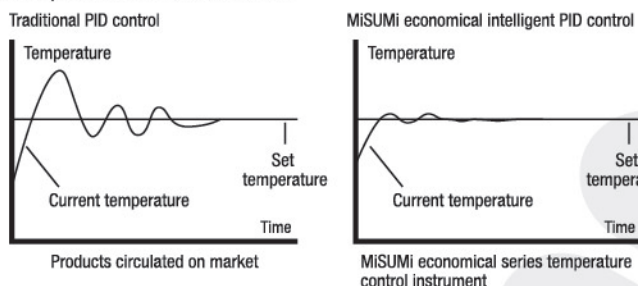

### C1 Function of Error Display

The instrument will display a message after self-diagnosis if it cannot work properly.

Message	Description	Troubleshooting
UUUU	Input disconnection, reverse polarity or out of input range	Check if the input signal is wrong
0000	Input disconnection, reverse polarity or out of input range	Check if the input signal is wrong

### C2 Diagram of Wiring Examples

The following wiring diagram is only for wiring instructions, and the actual wiring is subject to the wiring diagram of the instrument housing.

Model: C-MTCTRS

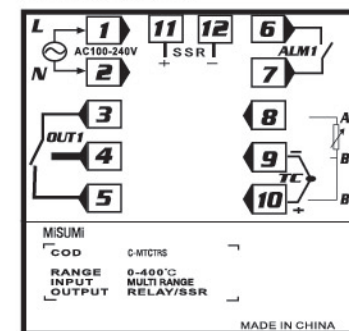

Model: C-MTCTRST (including RS485 communication)

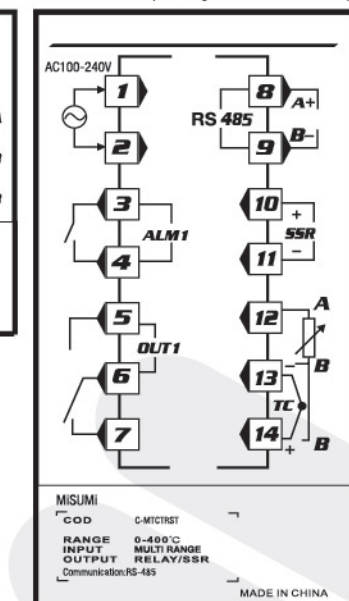

### C3 Instrument Simple Troubleshooting and Maintenance

- Connect the instrument correctly before powering on. The PV window displays the measured value, and the SV window displays the control value.
- There is neither display nor output action after the instrument is powered on.
  - First check whether the power supply wiring of the instrument is correct.
  - Check whether the power supply of the instrument is consistent with that of the input.
  - Use the instrument to measure whether the input power is abnormal.
- After the instrument is powered on, the PV window shows "UUUU" or "0000" abnormal display.
  - The display of "UUUU" or "0000" indicates that the signal input part of the instrument is abnormal.
  - First check whether the signal input wiring of the instrument is correct.
  - Check whether the sensor specifications are consistent with the instrument input specifications.
  - Check whether the sensor is connected reversely or damaged (open circuit or short circuit).
- There is no output after the instrument is powered on, but the corresponding indicators display normally.
  - First check whether the output wiring of the instrument is correct.
  - Check whether the output mode of the instrument matches the external load.
  - Check whether the external load of the instrument is damaged (open circuit or short circuit).
- The display or control of the instrument is abnormal.
  - First check whether the wiring of the instrument is correct.
  - Check whether the parameter settings of the instrument are reasonable.