

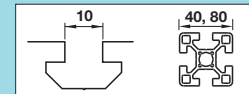

Brackets

-For Slot Width 10mm (Series 8) Aluminum Frames 40, 80mm Square-



CAD Data Folder Name: 37_Aluminum_Frames

Ordering Example	Part Number	HBLSS8
	Example	



Type	Material	Surface Treatment
HBLBSL8	S45C	Trivalent Chromate
HBLBCB8		
HBLBS8		
SHBLBS8	SCS13	
SHBLBCB8		
HBLFTD8	ADC12	
HBLFUD8		
HBLCS8-B	ADC12 Cap: Polyamide	
HABLBS8	SCS13 Nut: SUS304 Sintered Alloy Set Screw: SUS304	
NBLUT8	A6063S-T5	Anodize
NBLUQ8	A6063S-T5	
Others	AGN01SS-T5	

Sheet Metal Brackets P.1869

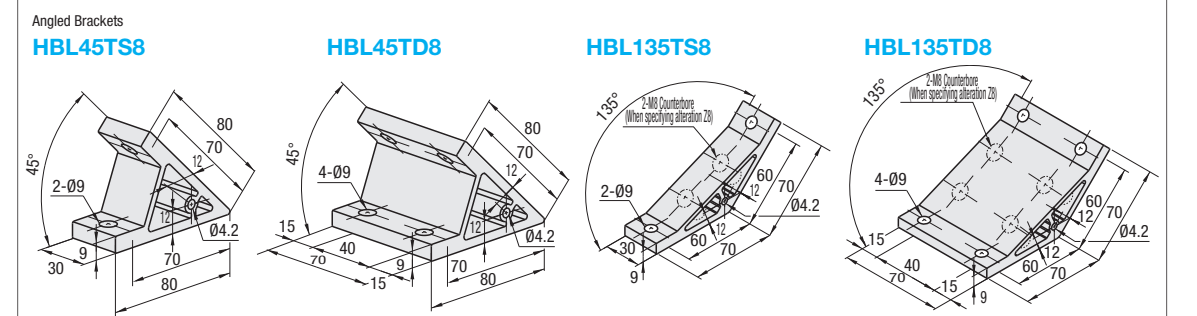
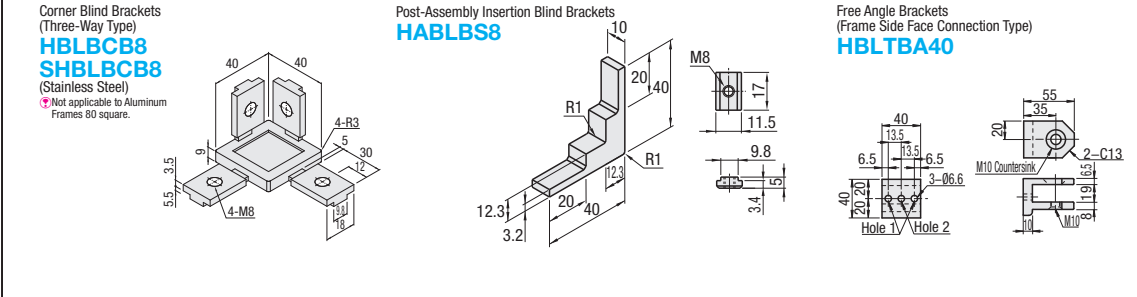
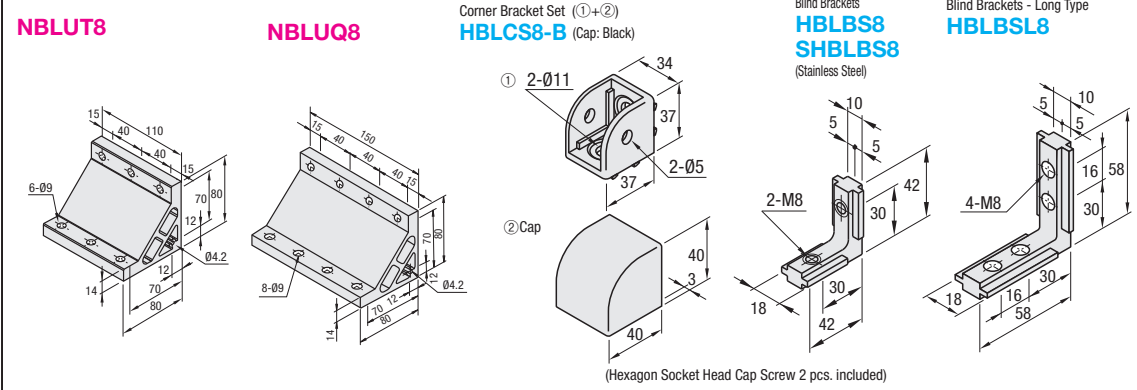
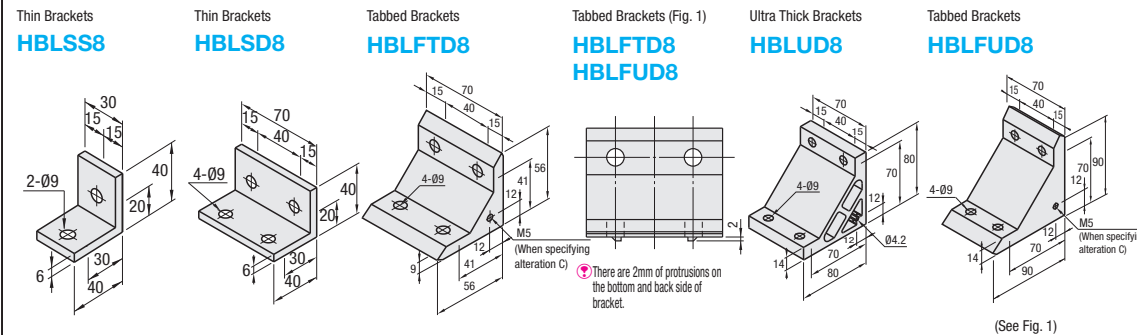
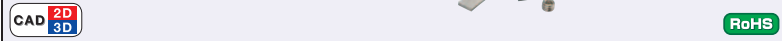

Part Number	Mass (g)	Applicable Bolt and Nut		Quantity	Allowable Load (N)
		Bolt	Nut		
HBLSS8	34	CBM8-15	HNTT8-8	2	1666
HBLSD8	80	CBM8-20		4	2352
HBLFTD8	140	CBM8-20		4	3087
HBLUD8	380			4	3920
HBLFUD8	370	CBM8-25		6	5292
NBLUT8	564			8	7056
NBLUQ8	770			8	800
HBLCS8-B	64	CBS12-30		2	1274
HBLBS8	70	Set Screw M8x10 (Included)		4	1554
SHBLBS8	87			2	1274
HBLBSL8	70			2	700
SHBLBCB8	47	Set Screw M8x6 (Included)	Nut (Included)	2	700
HABLBS8	97	M10x16 (Included)		1	-
HBLTBA40	88			2	2058
HBL45TS8	204	CBM8-20	HNTT8-8	4	2940
HBL45TD8	204			2	2058
HBL135TS8	103			4	2940
HBL135TD8	240			4	2940

Alterations Part Number HBL45TS8 - C-SCT

• C / SET / SST / SEU / SSU / SEP / SSP / SEC / SET1 / SET2 3 Days

• Z8 5 Days

Days to Ship

• Others Stock

• Stock lineup may vary by country.

• Same day shipping available upon request.

Order by THA: 16:00, SGP: 12:00, MYS: 15:00 P.75

• NBLUT8 / NBLUQ8 / HBLCS8-B / HBLBCB8 / SHBLBCB8 / HBL135TD8 3 Days

Order Quantity	Standard Service	
	Regular Quantity	Large Quantity
Quantity	1-120	121~
Days to ship	Standard	To be quoted

Alterations	Code	Spec.	Applicable Bracket
Mounting Holes for Cover	C	Adds a tap for a bracket for cover mounting. (M5 on Both Sides, Depth 15mm) (Mounting Screw P.1879 HCBM)	HBLFTD8 HBLFUD8 NBLUT8 NBLUQ8 HBL45TS8 HBL135TS8
Applicable Bolts and Nuts come as a set	SET SST (Stainless Steel) SEU (Pre-Assembly Insertion Spring Nuts) SSU (Pre-Assembly Insertion Spring Nut Stainless Steel) SEP (Post-Assembly Insertion Spring Nuts) SSP (Post-Assembly Insertion Spring Nut Stainless Steel) SEC (Washer Integrated Bolts, Nuts)	Supplies a set of applicable bolt and nuts for fixing the bracket to an extrusion. (Adds to the bracket price)	HBLSS8 HBLSD8 HBL45TS8 HBL45TD8 HBL135TS8 HBL135TD8
Machines 2 counter bored holes on 135 Degree	Z8	Adds two counterbored holes on HBL135T□8. (Applicable Bolts: M8)	HBL135TS8 HBL135TD8

Alterations	Code	How to Use	Part Number	Accessory		
				Type	Bolt	Nut
Applicable Bolts and Nuts come as a set	SET1 SET2	Use the hole 1. Use the hole 2.	HBLTBA40	CBM8-20	HNTT8-6	1

