



Single Axis Robots RSD2 - Rod Type



CE Compliant

See notes on CE Marking. P.49

CAD Data Folder Name: 07_Actuator

When placing order, select part numbers and values by proceeding through Selection Steps 1~7.

Ordering Example

Part Number (Type, 1 Lead, 2 With or w/o Brake)	3 Motor Mounting Direction	4 Controller	5 I/O Module	6 Cable Length	7 Stroke	
RSD206B	L	C1	N	3	200	(Motor Mounting Direction: L)
RSD206B	-	C1	N	3	200	(Motor Mounting Direction: Straight)
RSD206B	L	P1	-	3	200	(Motor Mounting Direction: L, Controller: P1)



Components: Actuator, Controller, Cable

Accessory

Controller I/O Specifications			
Accessory	NPN, PNP	CC-Link	DeviceNet
	Instruction Manual (CD-ROM), Power Connector, Dummy Connector, 6 Mounting Nuts		
		CC-Link Connector	DeviceNet Connector

Robot Material / Surface Treatment

Components	Body	Rod	Cover
Material	Aluminum	Steel	ABS
Surface Treatment	Acrylic Paint	-	-

General Specifications

Ball Screw	Motor	Position Detector	Operating Ambient Temperature, Humidity
Ø8 (C10 Rolled)	Stepping	Resolver (Incremental)	0~40°C, 35~85%RH (No Condensation)

Controller Specifications P.103~112

Standard Specifications P.110

Type	Lead (mm)	Positioning Repeatability (mm)	Max. Load Capacity (kg)	Max. Push Force (N)	Rated Running Life (1)	Lost Motion (mm)	Rod Non-Rotational Accuracy (degrees)	Stroke (mm)	Max. Velocity (mm/sec) (2)	Input Power Supply	Maximum Positioning Point
RSD2	02	±0.02	45	25	5,000 km or More	0.1 or Less	±1.0	50~300 (50 Pitch)	-80	DC24V ±10%	255 points
	06		40	12					-250		
	12		25	5					-500		

1. The service life in the vertical use may vary depending on the load capacity. Please refer to the "Service Life Table." 2. The maximum velocities may vary depending on the load capacity. Please refer to the "Velocity - Maximum Load Capacity Table."

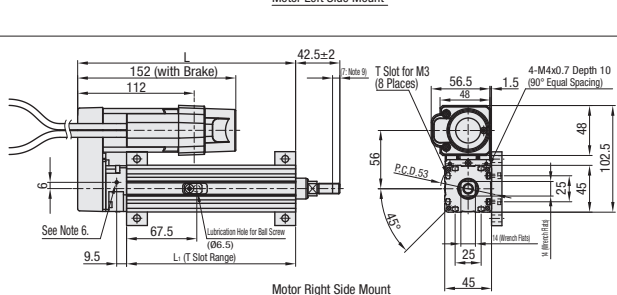
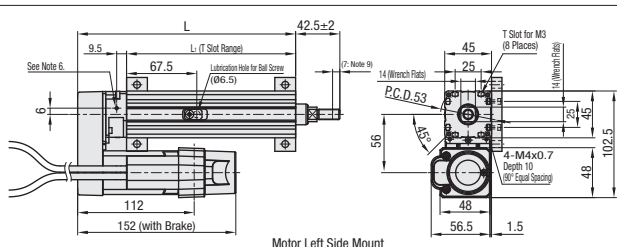
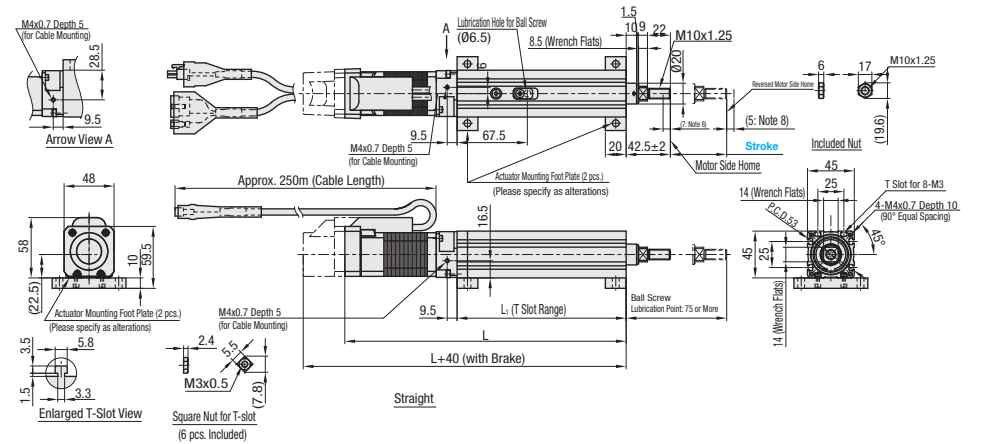

Note 1. Load can be applied only in axial direction. Please use externally mounted guides together to avoid application of radial loads on the rods.
 Note 2. Orientation of the wrench flats is not fixed in relation to the base surface.
 Note 3. In order to ensure running straightness, use externally mounted linear guides.
 Note 4. Reversed Motor Side Home cannot be set in case of Lead 2mm specifications.
 Note 5. The cable should be fastened without excessive strains.
 Note 6. The M4 hex-socket head screw can be utilized to fasten the cable (effective screw depth is 5mm).
 Note 7. The minimum bending radius of the cable is 30mm.
 Note 8. The brake adds 0.2 kg to the masses.
 Note 9. Indicates the distance to the mechanical stopper.

Part Number		Selection						
Type	1 Lead (mm)	2 With or w/o Brake (1)	3 Motor Mounting Direction	4 Controller (2)	5 I/O Module	6 Cable Length (m)	7 Stroke (mm)	
RSD2	02	W/o Brake: Leave blank With Brake: B	Straight: Leave Blank Right Side Mount: R Left Side Mount: L	Point Control: C1 Pulse Control: P1 (DC24V ±10%)	NPN: N PNP: P CC-Link: C DeviceNet: D	1 3 5 10 (Flexible Cable)	50~300 (50mm Increment)	
	06							
	12							

1) Choose the "With Brake" option for use in vertical applications. 2) When the pulse train type controller is selected, the I/O type selection is not required.

Dimensions / Mass

Type	Dimensions · Mass	Motor Mounting Direction: Straight						Motor Mounting Direction: R/L					
		Stroke (mm)						Stroke (mm)					
		50	100	200	250	300	50	100	150	200	250	300	
RSD2	L1 (mm)	162.5	212.5	262.5	312.5	362.5	412.5	162.5	212.5	262.5	312.5	362.5	412.5
	L (mm)	270.5	320.5	370.5	420.5	470.5	520.5	209.5	259.5	309.5	359.5	409.5	459.5
	Mass (kg) (Note 8)	1.4	1.7	1.9	2.2	2.4	2.7	1.6	1.9	2.1	2.4	2.6	2.9

The brake adds 0.2 kg to the total mass.

Note

Power interruption circuit is not provided in this controller in order to provide maximum flexibility for customer specific safety scheme. Please be sure to provide an external power interruption circuit and form an emergency stop circuit. For Circuit examples see P.109.

FAQ

- Q1. The actuator does not move.
A1. When activating an actuator using Support Software or Handset Terminal, invalidate Option Parameter (No. 80). (Option Valid = I/O Terminal Valid, Option Invalid = I/O Terminal Invalid). Then turn the servo status "ON" and operate the homing procedure. After the completion of homing, start the operation by turning on "Operation".
- Q2. LED light is on. Is there a controller defect?
A2. Blue: PWR (OFF: Control Power Shutdown, Blink: Servo OFF, ON: Servo ON), Red: ERR (OFF: Control Power Shutdown / No Error Alarm, Blink: Error Alarm On (External Factor), ON: Error Alarm On (Internal Factor))
- Q3. Teaching cannot be conducted by via I/O.
A3. To conduct teaching via I/O, the status needs to be ON for MANUAL Input and OFF for Interlock Input. Note that it does not function in the state of "Homing Incomplete".
- Q4. Is low-speed operation possible?
A4. Possible, however, 10 to 20% of max. velocity is the limit depending on the lead.

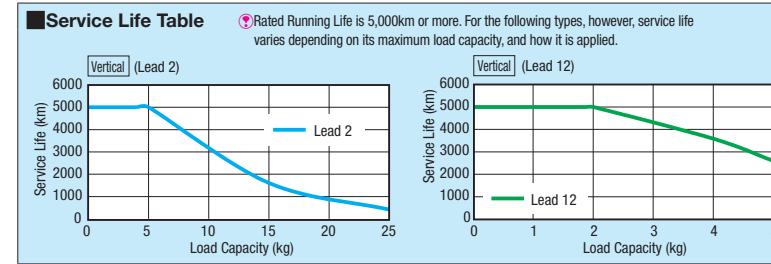
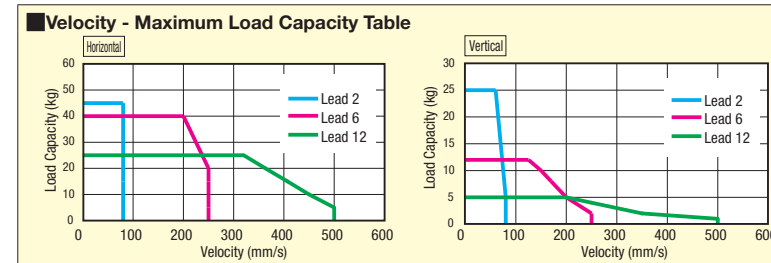

Days to Ship: 7 Days (Motor Mounting Direction: Straight), 10 Days (Motor Mounting Direction: R/L)

Alterations: Part Number RSD206B - Motor Mounting Direction L - Controller Type C1 - I/O Type N - Cable Length 3 - Stroke 200 - (G, E, etc.) G-E

Alterations	Handset Terminal Standard Specification	Handset Terminal w/ Deadman's Switch	Support Software w/ USB Communication Cable	Support Software w/ D-Sub Communication Cable	I/O Cable	Cable for daisy-chain connection	Instruction Manual ME5: Body KE3: Controller (C1) KE4: Controller (P1) Details P.120	Main Body Plastic Color Alterations	Actuator Mounting Foot Plate	Actuator Mounting Flange
Code	H	D	S	R	T/TP	C	ME5/KE3/KE4	BC	HP	VP
Spec.	Handset Terminal is included. Specifications P.109~113	Handset Terminal w/ Deadman's Switch is included. Specifications P.109, 113	Support Software w/ USB Communication Cable is included. Specifications P.109, 113	Support Software w/ D-Sub Communication Cable is included. Specifications P.109, 113	I/O Cable is included. Required for NPN/PNP configurations. Specifications P.109, 113	A cable to connect multiple controllers. Up to 16 controllers max. can be connected. Specifications P.111~113	Operation Manual is included.	Change the actuator plastic parts color to black.	2 plates are included for horizontal mounting. Specifications P.113	1 plate is included for vertical mounting. Specifications P.113

For optional items, see P.113. It is more economical to order the optional items as alterations than purchasing them individually. Entering point data requires the handy terminal or the support software. An I/O Cable is required for Parallel Communication I/O Control. For details on daisy-chain, see P.111, 113. Please select the correct I/O cable type for the appropriate controller type.