



MISUMI
C-VALUE

Precision Ball Screws Standard Nut - Shaft Dia. 15; Lead 5, 10, 20 (C-BSSH) Accuracy Grade C5

For how to select Ball Screws, see P. 2223

Points of comparison between similar products

Load rating, axial clearance and nut dimensions of C-VALUE products are different from those of similar products. (For details, see P. 715 to P. 716.)
When opting for C-VALUE products, select them by comparing specifications of similar products.

Similar Product Pages P. 715, P. 716

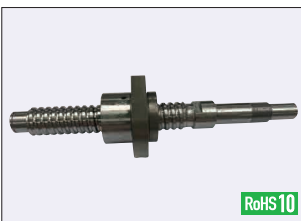

Nut Type	Type	Accuracy Grade	Shaft Dia.	Lead	Screw Shaft		Nut	
					Material	Hardness	Material	Hardness
Standard Nut	C-BSSH	C5	15	5, 10, 20	S55C	Induction Hardened 58-62 HRC	SCM415	Carburized 58-62 HRC

C-BSSH1505

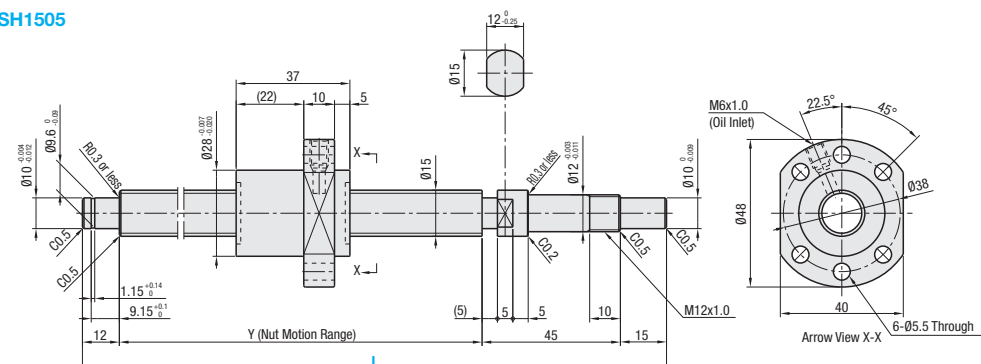

C-BSSH1510

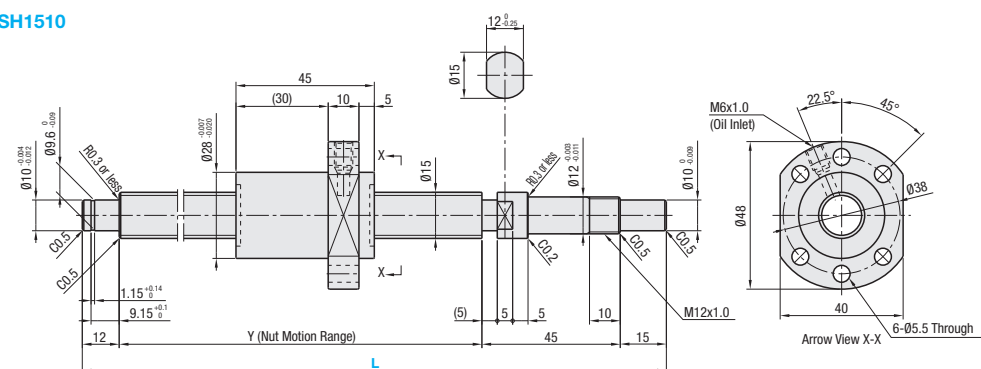

C-BSSH1520

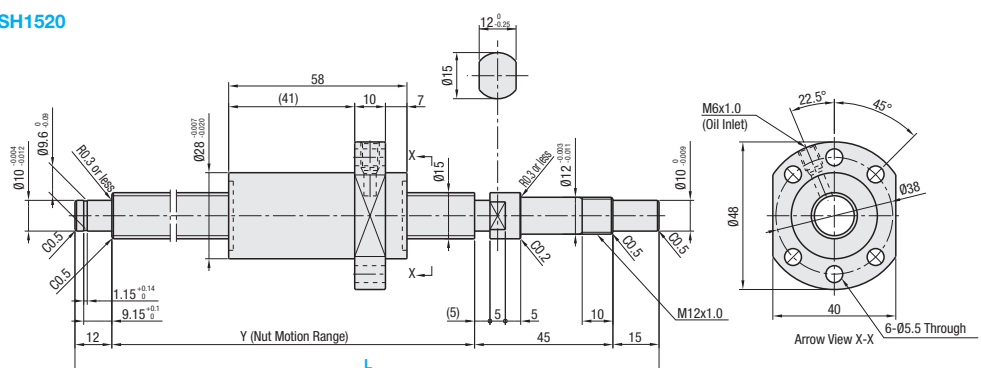

Nut Type	Accuracy Grade	Part Number Type	Screw Shaft O.D.	Lead	1 mm Increments L	Y	Ball Dia.	Ball Center Dia.	Screw Root Dia.	Number of Circuits	Basic Load Rating		Axial Play	Preload Torque N-cm	Twisting Direction
											C (Dynamic) kN	Co (Static) kN			
Standard Nut	C5	C-BSSH	15	05	150~1095	L - 72	2.778	15.672	(12.984)	3.8 turns, 1 row	4.8	8.8	0.015 or less	2.0 or less	Right
				10	200~1095					2.8 turns, 1 row	3.9	6.9		3.0 or less	
				20	230~1095					1.8 turns, 1 row	3.1	5.5			

kgf = N x 0.101972

Nut Type	Accuracy Grade	Part Number	JPY Unit Price: 1 to 4 pc(s).						
			L150~200	L201~400	L401~600	L601~800	L801~900	L901~1000	L1001~1095
Standard Nut	C5	C-BSSH1505							
		C-BSSH1510							
		C-BSSH1520							



Ordering Example
Part Number - L
C-BSSH1505 - 300

Notes

- Filled with lithium soap based grease (Alvania Grease S2 made by Showa Shell Sekiyu K.K.).
- For accuracy of Ball Screws, see P. 2223 and P. 2224.
- For details of Support Units, see P. 753 to P. 778.
- Cautions: Do not let the nuts overrun or remove the nuts from the screw shafts. It may cause the balls to fall out or damage the ball recirculation parts.
- Note that, when a ball screw shaft or ball screw nut is tilted, it may fall out due to its own weight.
- The collar included with the Support Unit product should be installed and tightened on the nut side of the ball screw.

[Do not let a nut overrun]

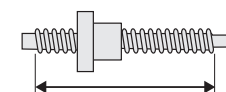

[Do not take a nut off]



Alterations
Part Number - L - (FC, KC...etc.)
C-BSSH1505 - 1000 - KC10

Alterations	Code	Spec.
No Machining on Support Side Shaft End	NC	No machining added on the support side shaft end. Ordering Code NC
Ball Nut Orientation Reversed (Support Side) (Fixed Side) Std. Revised	RLC	Changes the nut direction. Ordering Code RLC
No Retaining Ring Groove on Support Side Shaft End	RNC	No retaining ring groove is machined on the support side shaft end. Ordering Code RNC Combination with FC is not available.
Change Support Side Shaft End Length	FC	Changes the length of the support side shaft end. FC = 1 mm Increments Ordering Code FC20 13 ≤ FC ≤ 30 Y dimension is shortened. No Retaining Ring Groove Combination with FC is not available.
Change Support Side Shaft End Machining	GC	Changes the machining on the support side. Q is selectable from 8, 10 or 12. G = 1 mm Increments Ordering Code GC - Q8 - G20 5 ≤ G ≤ Q x 3 Y dimension is shortened. Combination with GC is not available.

Alterations	Code	Spec.
Tapped Hole on Support Side Shaft End	MC	Adds a tapped hole on the support side shaft end. MC = 1 mm Increments Ordering Code MC20 M 5 x 0.8 12 Y dimension is shortened. 18 ≤ MC ≤ 30
Keyway on Fixed Side Shaft End Detailed Keyway Dimensions P. 684	KC	Adds a keyway on the fixed side shaft end. KC = 1 mm Increments Ordering Code KC10 3 ≤ KC ≤ 14
Keyway on Fixed Side Shaft End	KLC	Adds a keyway at a customer specified area on the fixed side shaft end. (Keyway dim. is same as that of KC.) K, S = 1 mm Increments Ordering Code KLC - K5 - S3 4 ≤ K + S ≤ 14
Flat Machined on Fixed Side Shaft End	SC	Adds a flat on the fixed side shaft end. SC = 1 mm Increments Ordering Code SC7 5 ≤ SC ≤ 14
2 Flats Machined on Fixed Side Shaft End	SWC SGC	Adds two flats on the fixed side shaft end. SWC: 90° Position, SGC: 120° Position 1 mm Increments Ordering Code SWC10 5 ≤ SWC/SGC ≤ 14

Peripherals: Combination with the following parts is available.



Nut Brackets for C-Value Ball Screws are not available.

Combination with Support Units

Ball Screw Part Number Type	Screw Shaft O.D.	Lead	Recommended Support Unit		Shape	Fixed Side	Support Side	Page
			Part Number Type	No.				
C-BSSH	15	05 10 20	C-BRW	12	Round	○	○	P. 787
			C-BUR					P. 788
			C-BSW					P. 781
			C-BUN					P. 782

Other than the part numbers shown above, a rich variety of Support Units are also available. (P. 761 - P. 778)

