

Points on Similar Product Comparison | Travel Accuracy (Straightness) 50-60µm

Similar Product Pages P.1956

Features: Economically priced long stroke Rack & Pinion stages.

Z-Axis, Long

ZDTLS80 **Arrow View A**

ZDTLS100

ZDTLS150

Material: Aluminum Alloy
Surface Treatment: Black Anodize

X-Axis P.1907 RoHS 10

Z-Axis Stages High Precision Stage Existing Product: ZLWG (P.1956)

Part Number	Stage Surface (mm)	Travel Distance (mm)	Travel per Rotation (mm)	Load Capacity (N)	Travel Accuracy Straightness	Weight (kg)	Unit Price
ZDTLS 80	30x50	±30	16.7	14.7	50µm	0.16	
ZDTLS 100		±35			60µm	0.19	
ZDTLS 150		±65			60µm	0.24	

Resolution (Vernier Scale Indication): 0.1 mm/division

Knob Cover HDCVR15 (Sold Separately): Ø15 knobs can be increased in diameter by installing the cover. P.2004

Ordering Example
Part Number: ZDTLS100

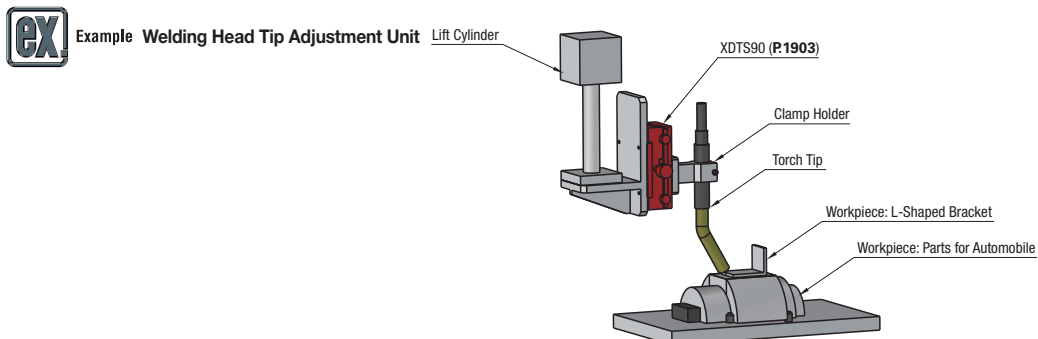

Features: Long stroke stages made of lightweight aluminum alloy. Length is selectable in accordance with the stroke required.

Z-Axis, Long

ZLWG
(L=50, 70, 100, 150, 150-2)

Material: Aluminum Alloy
Surface Treatment: Black Anodize
Accessory: CBST4-12 (2 pcs.)

The scale shown is for L100. Scales will be different for L50, L70, L150, and L150-2.
By turning the preload adjustment screw (A) clockwise with a flathead screwdriver, the stage slides slowly, and by turning counterclockwise the stage slides quickly and smoothly.
See the CAD data for details.

X-Axis P.1904

Standard Stages Similar Products (available for limited sizes only): ZDTLS (P.1955)

Part Number	L	Number of Blocks	Travel Distance (mm)	Travel per Rotation (mm)	Load Capacity (N)	Travel Accuracy Straightness	Weight (kg)	Unit Price
ZLWG	50	1	±15	18	14.7	30µm	0.120	
	70	1	±25				0.135	
	100	1	±40				0.160	
	150	1	±65			0.215		
	150-2	2	±44			0.285		

Resolution (Vernier Scale Indication): 0.1 mm/division

Knob Cover HDCVR15 (Sold Separately): Dovetail Stage Ø15 knobs can be increased in diameter by installing the cover. P.2004

ZLWG150-2 has two blocks. Please note that the stroke distances will be shorter than the one block versions.

Ordering Example
Part Number: ZLWG100