

# [Motorized] XYZ-Axis Linear Ball



For CAD data, see the MISUMI website.

Features: Integrated Linear Ball Slide Guides with High Precision and rigidity.

## XYZ-Axis Motorized Stage



- M** Material: SUS440C Equivalent
- S** Surface Treatment: Electroless Nickel Plating
- A** Accessory XYZMSG 413, 513: SCB3-8 (4pcs.)
- A** Accessory XYZMSG 615, 715: SCB4-8 (4pcs.)

For Controllers, Handset Terminals, see P.1-2014-1-P.1-2014-2 The Hex Wrench dedicated for tightening XY-bottom axis is included with. \* The sensor cover position shown on the photo is L (Standard). **RoHS 10**

The drawings are for the R (right) Cover Position Type.

### XYZMSG413

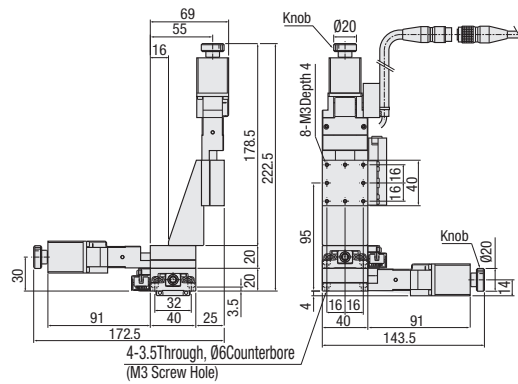

### XYZMSG513

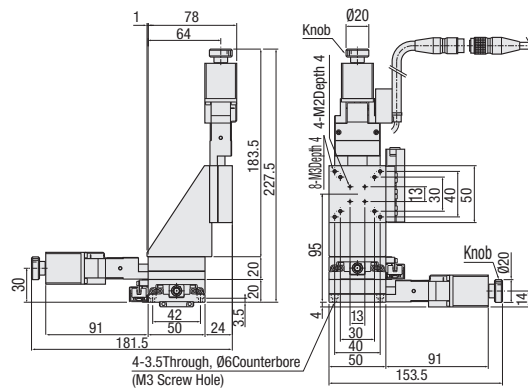

### XYZMSG615

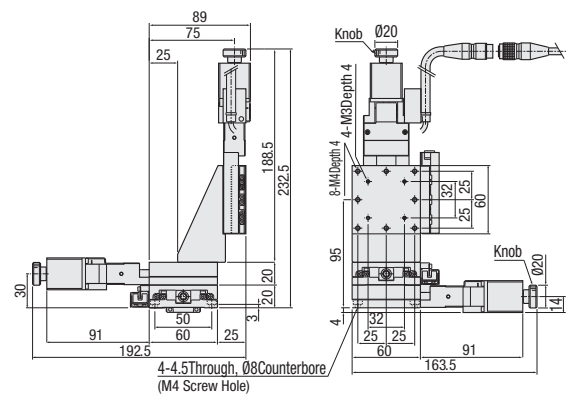

### XYZMSG715

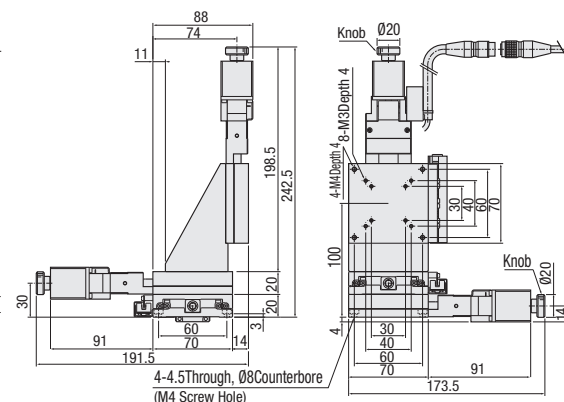

Part Number	Sensor			Motor	Cable	Mechanical Standards			Accuracy Standards <sup>4</sup>			
	Type	No.	Cover Position			Logic	Voltage (V)	Stage Surface (mm)	Travel Distance (mm)	Weight <sup>3</sup> (kg)	Unidirectional Positioning Accuracy	Pitching
XYZMSG	L (Standard) R (Reversed)	413	A (All N.C.) B (All N.O.) C (Limit Switches are N.C., Home Sensor is N.O.)	5 <sup>1</sup> 24 <sup>1</sup>	C (Standard) D (High Torque) E (High Resolution) MA <sup>2</sup> (With Electromagnetic Brake) PA <sup>2</sup> (g-Step) UA <sup>2</sup> (Servo Motor)	N (Cable not included (separately sold)) M <sup>2</sup> (For Motor with Electromagnetic Brake) P <sup>2</sup> (For g-Step) U <sup>2</sup> (For Servo Motor) * For combination of motors and cables, see the table below.	40×40	13	0.6	6µm or less	15" or less	10" or less
		513					50×50		0.8			
		615					60×60	15	0.9			
		715					70×70	1.2				

- \*1 24VDC sensors cannot be operated from the MSCTL102/112 controller. When selecting 5V for voltage configuration, applying over 5V voltage will cause breakage.
- \*2 For motor options MA and PA, the driver is included in the set. For motor option UA, the amp is included in the set. With motor option MA, only cable option M is selectable. With motor option PA, only cable option P is selectable. With motor option UA, only cable option U is selectable. In all three cases, cable option N (no cable) is not selectable.
- \*3 The value is for C Type of Motor.
- \*4 Accuracy specifications are for single axis (horizontal orientation) configuration.

Ordering Example: **Part Number** - **Sensor** - **Motor** - **Cable**  
 XYZMSG413 - LA5 - C - N

Days to Ship **Configure Online**

### Common Specifications

Feed Screw	Ball Screw Ø6, Lead 1
Guide	Linear Ball Guide
Resolution <sup>*1</sup>	2µm/Pulse (Full) 1µm/Pulse (Half)
Positioning Repeatability	Within ±0.5µm
Load Capacity	49N
Lost Motion	1µm or less
Backlash	0.5µm or less
Parallelism	15µm or less

- \*1 Stage travel per one pulse.
- \* Accuracy specifications are for single axis (horizontal orientation) configuration.

### Motor/Cable Application Table

Motor	Cable
C, D, E	N (Not Provided)
MA	M
PA	P
UA	U

For the cable for C, F or G, see MSCB1 on P.1-2014-3

### Max. Speed

Motor	(mm/sec)	Motor	(mm/sec)
C	10	MA	10
D	25	PA	30
E	20	UA	50

Note that the speed and positioning time will vary depending on the usage conditions. The values shown here are MISUMI's reference values. Operation at these values is not guaranteed.

### Electrical Specifications

<b>Motor</b>	<b>Type</b> 5-Phase Stepping Motor 0.75A/Phase (Oriental Motor Co., Ltd.)
	<b>Step Angle</b> 0.72°
<b>Compatible Receptacle Connector</b>	HR10A-10P-12S (Hirose Electric Co., LTD.)
<b>Current Consumption</b>	100mA or less (25mA per Sensor)
<b>Control Output</b>	NPN Open Collector Output DC5 ~ 24V, 16mA or less Residual Voltage 1V or less (when load current is 16mA)
<b>Sensor</b>	N.C ●●● Light seen N.O ●●● Light blocked
<b>Output Logic</b>	<Internal Circuit>  K: Emitter Cathode V: Receptor Supply+ A: Receptor Anode O: Output G: Receptor Supply-

### Connector Pin Configuration

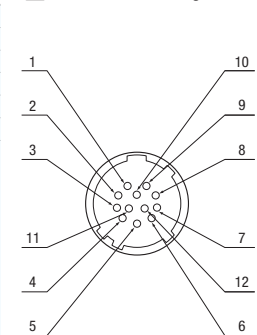

### Connecting Diagram

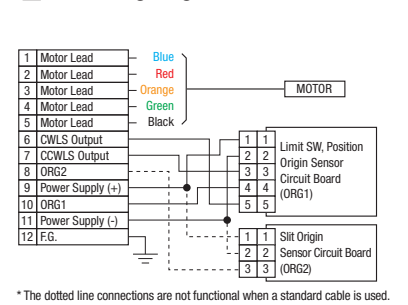

### Included Sensor Timing Chart (for A Sensor Logic)

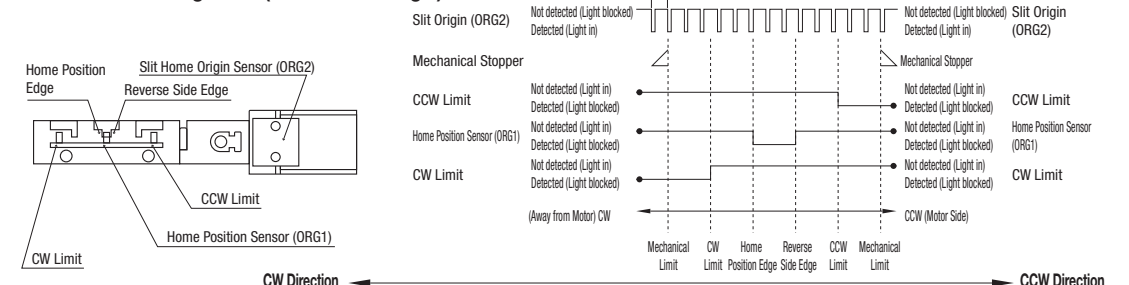

Travel Distance	Reference Position	Mechanical Limit	CW Limit	Home	Other Signal Edge	CCW Limit	Mechanical Limit
13	Homing	8	7.5	0	2	6.5	7
15	Homing	9	8.5	0	2	7.5	8
30	Homing	16.5	16	0	2	15	15.5
50	Homing	26.5	26	0	2	25	25.5

Common Slit Home Position (Detecting) Interval S=1

- Homing Routine Above: When MSCTL102/112 controller is used and when the Homing Routine Type 3 (see below) is executed. (Unit: mm)
- The coordinates shown are design values. There may be approx. ±0.5mm misalignment on the physical dimensions.

### Recommended Homing Method

- Type3** After detection is executed in the CCW direction, the process of detecting in the CW direction is begun based on the ORG signal.
- Type4** After detection is executed in the CW direction, the process of detecting in the CCW direction is begun based on the ORG signal.
- Type9** After Type 3 is executed, the process of detecting in the CCW direction is begun based on the TIMING signal.
- Type10** After Type 4 is executed, the process of detecting in the CW direction is begun based on the TIMING signal.