



Patented

Single / Double / Flanged Single

Long Term Maintenance Free Lubrication Unit MX Characteristics and Features

Features of Lubrication Unit MX

- Extended maintenance period**
Long durability of lubrication performance has resulted in significant reduction of maintenance load especially with machines and equipment environments where applying grease is not easy.
- Environmentally friendly system**
Proper amount of lubricant to ball rolling surface at right time makes the system environment-friendly.
- Cost advantage**
Contributes to reduction of maintenance costs and product troubles caused by failing to lubricate.
- Reduced manufacturing steps**
No need to fill with grease prior to use because the product is already filled with Lithium soap-based grease in addition to the built-in lubrication unit.

Structure of Lubrication Unit MX

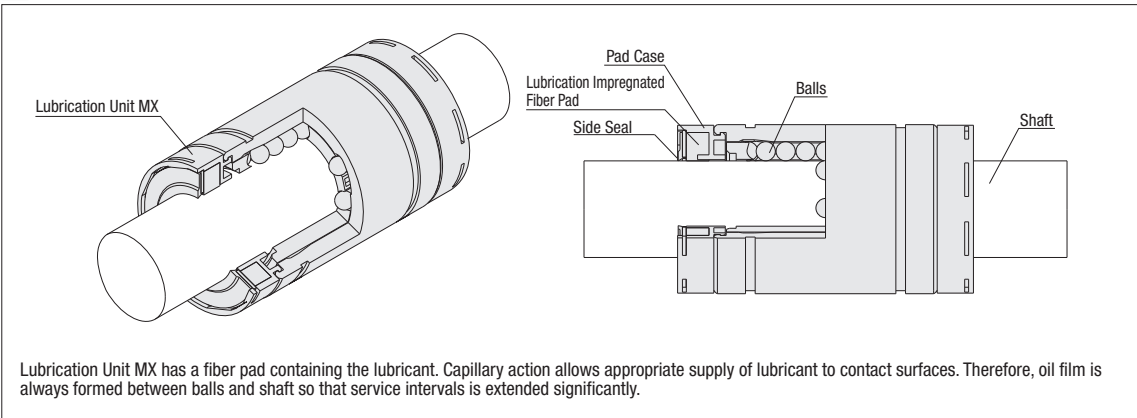

2.5x durability with a little cost addition to the Standard Type

Endurance Test Result

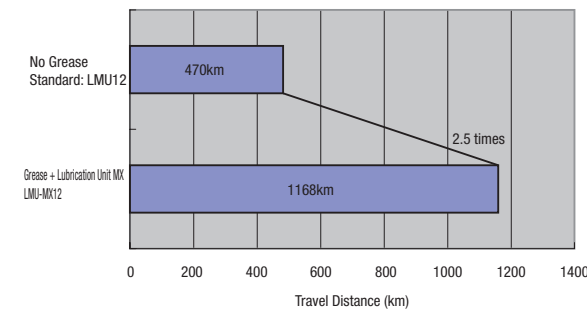

<Test Condition>

Sample : Linear Bushing LMU12 with Anti-rust oil,
Linear Bushing with Lubrication Unit LMU-MX12
Applied Load : 206N (50% against Basic Dynamic Load Rating 412N)
Average Speed : 42m/min(0.7m/sec)
Stroke : 100mm
Lubricant : Grease, initial filling only (LMU-MX12 only)
Shaft Material : SUJ2 58HRC
24 hours, continuously operated

With 50% of basic load rating applied for testing, the Lubrication Unit MX Type has shown a 2.5 times higher durability performance compared to the one without the MX lubrication unit.

*The data above are for reference only, and not guaranteed by the manufacturer.
The data was revised to the above since the 2007 catalog after the safety margin was confirmed by increased test data points.

Handling Cautions

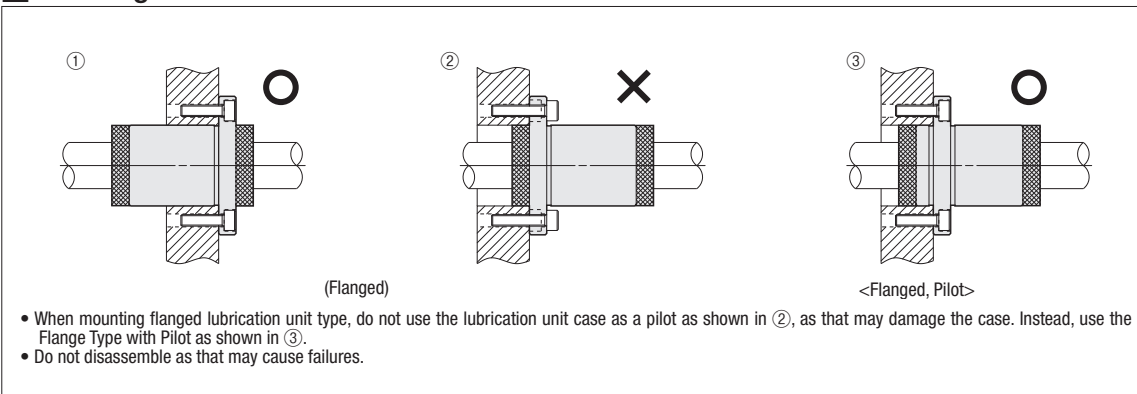

Lubrication Unit **MX** realizes maintenance free.

Features: The most popular Linear Bushing style.

MISUMI Original



Type	Outer Cylinder	Balls	Pad Case / Retainer	Ambient Operating Temp.	Accessory
Single	Material: SUJ2 Equivalent, Hardness: 58HRC~	Material: SUJ2 Equivalent	Material: Plastic (Duracon M90 Equivalent)	-20~80°C	Seal Material: Nitrile Rubber

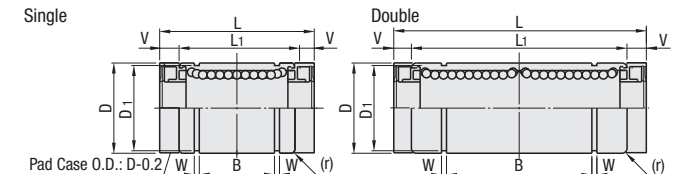

No need to fill with grease prior to use because the product is already filled with lithium soap-based grease in addition to the built-in lubrication unit.

Single

Part Number	Type	dr	Tolerance	D Tolerance	L	L1 Tolerance	V	B Tolerance	W	D1	(r)	Eccentricity (Max.)	Rows of Balls	Basic Load Rating C (Dynamic) N / Co (Static) N	Mass (g)	
LMU-MX 10	10	0	19	0	39	29	5	19.4	1.3	18	0.4	0.012	4	372	549	35
LMU-MX 12	12	-0.009	21	-0.013	41	30	5.5	20.4	1.6	20	0.8	0.015	5	412	598	45
LMU-MX 16	16	0	28	0	49	37	6	23.3	1.85	27	1.5	0.020	6	775	1180	80
LMU-MX 20	20	0	32	0	56	42	7	27.3	2.1	30.5	0.020	6	882	1370	109	
LMU-MX 25	25	0	40	0	77	59	9	37.8	2.6	38	0.020	6	980	1570	255	
LMU-MX 30	30	-0.010	45	-0.016	84	64	10	40.8	2.6	43	0.020	6	1570	2740	286	
LMU-MX 35	35	0	52	0	92	70	11	45.3	2.6	49	0.020	6	1670	3140	453	
LMU-MX 40	40	0	60	0	104	80	12	56.3	2.6	57	0.020	6	2160	4020	687	
LMU-MX 50	50	-0.012	80	-0.019	128	100	14	68.8	2.6	76.5	0.020	6	3820	7940	1763	

Double

Part Number	Type	dr	Tolerance	D Tolerance	L	L1 Tolerance	V	B Tolerance	W	D1	(r)	Eccentricity (Max.)	Rows of Balls	Basic Load Rating C (Dynamic) N / Co (Static) N	Allowable Static Moment (Mo N·m)	Mass (g)	
LMUW-MX 10	10	0	19	0	65	55	5	41.4	1.3	18	0.4	0.015	4	588	1100	7.24	66
LMUW-MX 12	12	-0.010	21	-0.016	68	57	5.5	43.4	1.6	20	0.8	0.020	5	657	1200	10.9	84
LMUW-MX 16	16	0	28	0	82	70	6	49.8	1.85	27	1.5	0.020	6	1230	2350	19.7	152
LMUW-MX 20	20	0	32	0	94	80	7	57.8	2.1	30.5	0.020	6	1400	2740	26.8	191	
LMUW-MX 25	25	0	40	0	130	112	9	78.3	2.6	38	0.020	6	1560	3140	43.4	459	
LMUW-MX 30	30	-0.012	45	-0.019	143	123	10	85.3	2.6	43	0.020	6	2490	5490	82.8	504	
LMUW-MX 35	35	0	52	0	157	135	11	94.8	2.6	49	0.020	6	2650	6270	110	823	
LMUW-MX 40	40	0	60	0	175	151	12	116.8	2.6	57	0.020	6	3430	8040	147	1203	
LMUW-MX 50	50	-0.015	80	-0.022	220	192	14	142.8	2.6	76.5	0.020	6	6080	15900	397	3163	

For Precautions for Use, see P.303.

kgf=Nx0.101972

Lubrication Unit **MX** realizes maintenance free.

Features: Easy to assemble with bolt-on flanges.

MISUMI Original



Type	Outer Cylinder	Balls	Pad Case / Retainer	Ambient Operating Temp.	Accessory
Round Flange: LHFR-MX, Square Flange: LHFS-MX, Compact Flange: LHFC-MX	Material: SUJ2 Equivalent, Hardness: 58HRC~	Material: SUJ2 Equivalent	Material: Plastic (Duracon M90 Equivalent)	-20~80°C	Seal Material: Nitrile Rubber

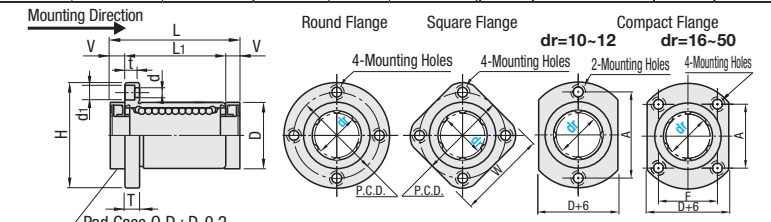

No need to fill with grease prior to use because the product is already filled with lithium soap-based grease in addition to the built-in lubrication unit.

Part Number	Type	dr	Tolerance	D Tolerance	L	L1 Tolerance	V	H	T	d	d1	t	P.C.D.	W	F	A	Eccentricity	Rows of Balls	Basic Load Rating C (Dynamic) N / Co (Static) N	Mass (g)			
LHFR-MX 10	10	0	19	0	39	29	5	40	6	4.5	7.5	4.1	29	30	-	29	0.012	4	372	549	76	56	68
LHFR-MX 12	12	-0.009	21	-0.016	41	30	5.5	42	6	5.5	8.5	4.5	32	32	-	32	0.012	4	412	598	80	61	72
LHFR-MX 16	16	0	28	0	49	37	6	48	7	6	10	5.1	38	37	22	31	0.015	5	775	1180	127	111	119
LHFR-MX 20	20	0	32	0	56	42	7	54	8	6.5	11	5.1	43	42	24	36	0.015	5	882	1370	191	156	178
LHFR-MX 25	25	0	40	0	77	59	9	62	8	7.5	12	5.1	51	50	32	40	0.015	5	980	1570	359	319	344
LHFR-MX 30	30	-0.010	45	-0.019	84	64	10	74	10	8.5	13	6.1	60	58	35	49	0.020	6	1570	2740	494	399	412
LHFR-MX 35	35	0	52	0	92	70	11	82	11	9.5	14	6.1	67	64	38	55	0.020	6	1670	3140	678	588	603
LHFR-MX 40	40	0	60	0	104	80	12	96	13	9	14	8.1	78	75	45	64	0.020	6	2160	4020	1093	913	946
LHFR-MX 50	50	-0.012	80	-0.022	128	100	14	116	14	11	16	8.1	98	92	56	80	0.020	6	3820	7940	2263	2063	2100

For Precautions for Use, see P.303.

Select Height-adjusting Spacers for Flanged Bushings from P.330.

Perpendicularity of D to flange mounting surface

kgf=Nx0.101972

dr	Straight Single	Straight Double	Round Flange	Square Flange	Compact Flange
	LMU-MX	LMUW-MX	LHFR-MX, LHFSM-MX, LHFCM-MX	LHFS-MX, LHFSM-MX, LHFCM-MX	LHFR-MX, LHFSM-MX, LHFCM-MX
	Unit Price	Unit Price	Unit Price	Unit Price	Unit Price
10	1 - 9 pcs, 10-20 pcs	1 - 9 pcs, 10-20 pcs	1 - 9 pcs, 10-20 pcs	1 - 9 pcs, 10-20 pcs	1 - 9 pcs, 10-20 pcs
12					
16					
20					
25					
30					
35					
40					
50					

Ordering Example
Part Number
LMU-MX16
LHFR-MX12
Various Grease Application Services are not applicable.

For orders larger than indicated quantity, please request a quotation.