



### Motor Adapter Plate Dimensional Drawing

Note: Note that the Motor Adapter protrudes beyond the rail at \* marked area.

<p><b>A4538 Servo</b> □ 38</p>	<p><b>A4540 Servo</b> □ 40</p>
<p><b>MA4560 Servo</b> □ 60</p>	<p><b>A4560 Servo</b> □ 60</p>
<p><b>E4540 Servo</b> □ 40</p>	<p><b>E4555 Servo</b> □ 55</p>
<p><b>T4560 Stepping</b> □ 60</p>	<p><b>T4585 Stepping</b> □ 85</p>
<p><b>T4556.4 Stepping</b> □ 56.4</p>	<p><b>F No Motor Bracket Type</b></p>

**Motor Adapter Centering Tool**

Material: A5056  
Surface Treatment: Clear Anodize

Part Number	D	Applicable Adapter Plate	d	D1	d1	L	T	ℓ	Unit Price 1-5pcs
30	30	A4538 / A4540 / T4556.4	15	25	10	62	22	20	
JIGLX45	36	T4560				62	22	20	
	50	A4560 / MA4560 / T4585				61.5	13.5		

For orders larger than indicated quantity, please check with WOS.

Ordering Example: Part Number - D  
JIGLX45 - 30

### Proximity Sensor (SUNX) - Set Part Specification

LX Part Number	Code (□ is Sensor Qty.) * Up to 3 Sensors	Sensor Type/Qty.		Sensor Rail		Sensor (* Qty per Sensor Included)		Sensor Flag		Unit Price (L≤440)			Unit Price (L≥490)										
		GX-F12A (ON when near)	GX-F12B (ON when away)	Rail (1 pc.)	Mounting Screw (Pitch +1 pc.)	Sensor Mounting Screw (1 pc.)	Mounting Nut (1 pc.)	Sensor Flag (1 pc.)	Sensor Flag Mounting Screw	Sensor Qty.	Sensor Qty.	Sensor Qty.	Sensor Qty.										
LX45 □ □ -B	XA □ □	-	-	SENC3 □ H	SCB3-5	CBSST3-8	LBNR3	Dedicated	Flat Head Machine Screw M3-5 (1 pc.)	1 pc.	1 pc.												
LX45 □ □ -S	XB □ □	-	-							1 pc.	2 pcs.												
LX45 □ □ -C-B	FA □ □	-	-							SCB3-6	SCB3-6 (2 pcs.)	SCB3-6 (2 pcs.)	SCB3-6 (2 pcs.)	SCB3-6 (2 pcs.)									
LX45 □ □ -C-S	FAS □ □	-	-												1 pc.	2 pcs.							
LX45 □ □ -B	FBS □ □	-	-												1 pc.	2 pcs.							
LX45 □ □ -S	XW1 □ □	1 pc.	1 pc.							SCB3-6	SCB3-6	CBSST3-8	LBNR3	Dedicated	Flat Head Machine Screw M3-5 (1 pc.)								
LX45 □ □ -S	XW2 □ □	2 pcs.	2 pcs.													1 pc.	2 pcs.						
LX45 □ □ -C-B	FW1 □ □	1 pc.	1 pc.													1 pc.	2 pcs.						
LX45 □ □ -S	FW2 □ □	2 pcs.	2 pcs.													1 pc.	2 pcs.						
LX45 □ □ -C-S	FW3 □ □	2 pcs.	2 pcs.													1 pc.	2 pcs.						
LX45 □ □ -C-S	FWS1 □ □	1 pc.	1 pc.	1 pc.	2 pcs.																		
LX45 □ □ -C-S	FWS2 □ □	2 pcs.	2 pcs.	1 pc.	2 pcs.																		
LX45 □ □ -C-S	FWS3 □ □	2 pcs.	2 pcs.	1 pc.	2 pcs.																		

### Photo Sensor (SUNX) - Set Part Specification

LX Part Number	Code (□ is the number of Sensors) * Up to 3 Sensors	Sensor Rail		Sensor (* Qty per Sensor Included)				Sensor Flag		Unit Price (L≤440)			Unit Price (L≥490)							
		Photo Sensor	Rail (1 pc.)	Mounting Screw (Pitch +1 pc.)	Sensor Bracket	Bracket Mounting Screw Nut	Sensor Mounting Screw	Sensor Mounting Washer	Sensor Flag (1 pc.)	Sensor Flag Mounting Screw	Sensor Qty.	Sensor Qty.	Sensor Qty.	Sensor Qty.						
LX45 □ □ -B	SP □ □	PM-L25	SENC3 □ H	SCB3-5	Dedicated	SCB3-5 (2 pcs.)	LBNR3 (2 pcs.)	M2 Small Flat Washer (2 pcs.)	Dedicated	Flat Head Machine Screw M3-5 (1 pc.)	1 pc.	2 pcs.	3 pcs.	1 pc.	2 pcs.	3 pcs.				
LX45 □ □ -S	MP □ □										SCB3-6	SCB3-6 (2 pcs.)	SCB3-6 (2 pcs.)	SCB3-6 (2 pcs.)						
LX45 □ □ -C-B	MP □ □										SCB3-6	SCB3-6 (2 pcs.)	SCB3-6 (2 pcs.)	SCB3-6 (2 pcs.)						
LX45 □ □ -C-S	MPS □ □																			

The Photo Sensor PM-L24 is to be discontinued and replaced by the next-generation product PM-L25 in April 2017.

### Photo Sensor (Omron) - Set Part Specification

LX Part Number	Code (□ is the number of Sensors) * Up to 3 Sensors	Sensor Rail		Sensor (* Qty per Sensor Included)				Sensor Flag		Unit Price (L≤440)			Unit Price (L≥490)							
		Photo Sensor	Rail (1 pc.)	Mounting Screw (Pitch +1 pc.)	Sensor Bracket	Bracket Mounting Screw Nut	Sensor Mounting Screw	Sensor Mounting Washer	Sensor Flag (1 pc.)	Sensor Flag Mounting Screw	Sensor Qty.	Sensor Qty.	Sensor Qty.	Sensor Qty.						
LX45 □ □ -B	OP □ □	EE-SX911-R1M	SENC3 □ H	SCB3-5	Dedicated	SCB3-5 (2 pcs.)	LBNR3 (2 pcs.)	M3 Small Flat Washer (2 pcs.)	Dedicated	Flat Head Machine Screw M3-5 (1 pc.)	1 pc.	2 pcs.	3 pcs.	1 pc.	2 pcs.	3 pcs.				
LX45 □ □ -S	EP □ □										SCB3-6	SCB3-6 (2 pcs.)	SCB3-6 (2 pcs.)	SCB3-6 (2 pcs.)						
LX45 □ □ -C-B	EP □ □										SCB3-6	SCB3-6 (2 pcs.)	SCB3-6 (2 pcs.)	SCB3-6 (2 pcs.)						
LX45 □ □ -C-S	EPS □ □																			

\* Sensors are not sold separately.  
EE-SX911-R1M is scheduled to change to EE-SX951-R1M from April 2015.

Alterations

Part Number - Block Qty. - Motor Adapter Plates - Base Length (L) - (Code)

LX4510 - B1 - A4540 - 590 - XW1  
LX4520C - B1 - A4560 - 340 - EP2

### Proximity Sensor Type Installation Drawings - SUNX

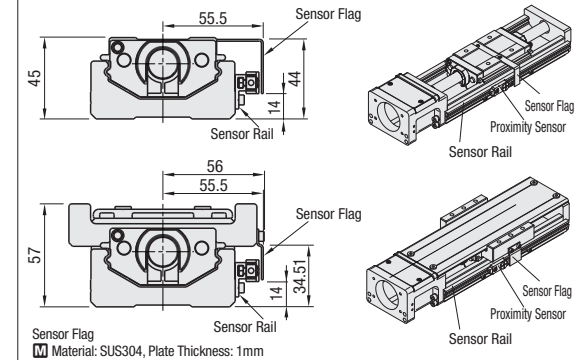

### Photo Sensor Type Installation Drawings - SUNX / Omron

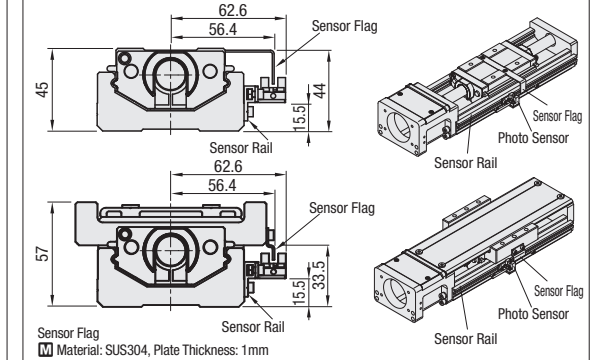

### Cautions

- Sensor set is shipped with LX Actuator. Assembly required.
- Please check for all included parts immediately after unpacking. Some small parts can be lost.
- Please handle the products with great care.

Please access each sensor manufacturer's website for the specifications of sensors in use.