

TAPERED PIN SET

—STANDARD TYPE—

ⓘ Non JIS material definition is listed on P.1351 - 1352

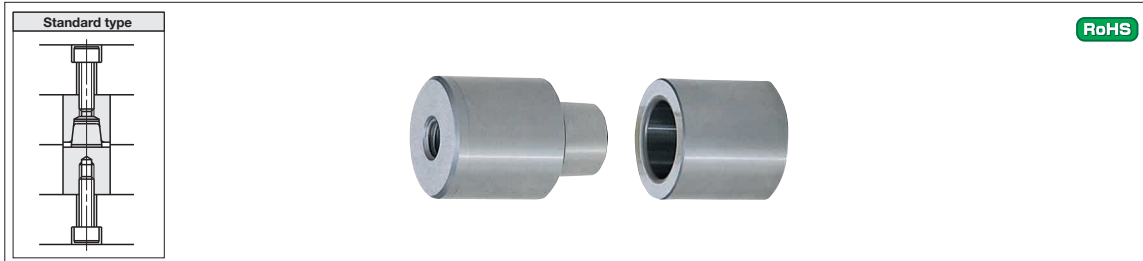

Group	Part Number			D	Components concentricity of tapered section to the diameter of pin and bushing	M	H
	Set	Pin only	Bushing only				
Standard	TPN	—	—	D _{k6}	(Match mark type)	SKD11 equivalent	58~62HRC
Precision	TPNV	TPNVP	TPNVB	D ^{+0.005} ₀	0.01 or less		
Extra Precision	VTPN	VTPNP	VTPNB		0.005 or less		
	ZTPN	ZTPNP	ZTPNB		0.003 or less		

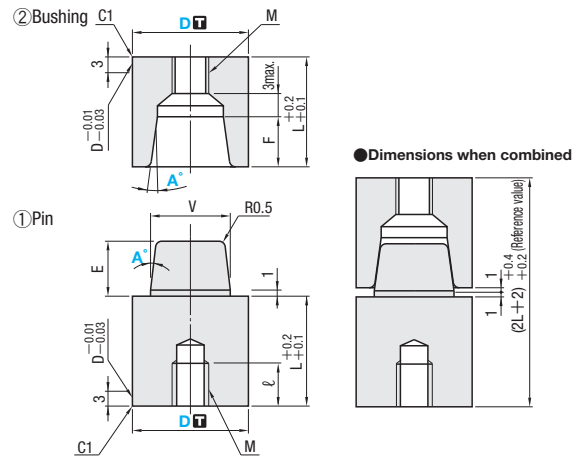

D	L	V	E	F	① Pin		② Setting	
					M	ℓ	tap for bushing	
8	13	5	6	5	M 3	7.5	M 3	
10	14	7	6	5	M 4	10	M 4	
13	14	7	6	5	M 4	10	M 4	
16	14	10	6	5	M 5	10	M 5	
20	19	13	9	8	M 6	12	M 6	
25	24	16	12	11	M 8	16	M 8	
30	29	20	15	14	M10	20	M10	
32	29	20	15	14	M10	20	M10	
35	34	24	18	17	M12	24	M12	
42	39	30	24	23	M12	24	M12	

■ Standard D_{k6} · match mark type

D _{k6}	Part Number		A°	U/Price 1~9 Set
	Type	D		
13	TPN	13	1	Quotation
16		16		
20		20		
25		25		
30		30		
32		32		
35		35		
42		42		

■ Standard D_{k6} · component concentricity 0.01 or less

D _{k6}	Part Number		A°	U/Price 1~9	
	Type	D		(①+②) Set	① Pin ② Bushing
10	TPNV (①+② Set)	10	1	Quotation	
13		13			
16		16			
20		20			
25		25			
30		30			
32		32			
35		35			

■ Precision D^{+0.005}₀ · component concentricity 0.005 or less

D tolerance	Part Number		A°	U/Price 1~9
	Type	D		
+0.005 0	VTPN (①+② Set)	8	1	Quotation
		10		
		13		
		16		
		20		
		25		

■ Extra Precision D^{+0.005}₀ · component concentricity 0.003 or less

D tolerance	Part Number		A°	U/Price 1~9
	Type	D		
+0.005 0	ZTPN (①+② Set)	8	1	Quotation
		10		
		13		
		16		
		20		

ⓘ ※A° (0.5) is only available for the set (ZTPN) sale.

- Before using a TPN (match mark type), align the match marks.
- When selecting a pin independently, use a combination of a pin and bushing of the same accuracy.

Order **Part Number** — **A**
TPN16 — 3

Price **Quotation**

Days to Ship **Quotation**

Alterations **Part Number** — **A** — (BLC · PLC · AC · BLK · PLK)
TPN16 — 3 — BLC12.0—PLC12.0—AC—BLK—PLK **Quotation**

Alterations	Code	Spec.	1Code	Alterations	Code	Spec.	1Code
	BLC	Shortens the bushing's L dimension. BLC=0.1mm increments L-2≤BLC<L ⓘ The tap depth becomes shorter by (L-BLC) ⓘ Available also for a set. To change the pin length as well, combine with PLC.	Quotation		BLK	Changes the bushing's L dimension tolerance. L ^{+0.2} _{+0.1} → L ^{+0.02} ₀ ⓘ Available also for a set. To change the pin length (L) tolerance as well, combine with alteration PLK. ⓧ Not applicable to the L dimension tolerance (reference valve) for a set.	Quotation
	PLC	Shortens the pin's L dimension. PLC=0.1mm increments L-5≤PLC<L ⓘ The tap depth becomes shorter by (L-PLC) ⓘ Available also for a set. To change the bushing length as well, combine with BLC.			PLK	Changes the pin's L dimension tolerance. L ^{+0.2} _{+0.1} → L ^{+0.02} ₀ ⓘ Available also for a set. To change the bushing length (L) tolerance as well, combine with alteration BLK. ⓧ Not applicable to the L dimension tolerance (reference valve) for a set.	
	AC	Air vent processing (single) A 0.3mm deep flat cutting is performed in parallel to the cone angle.					

How to Mount

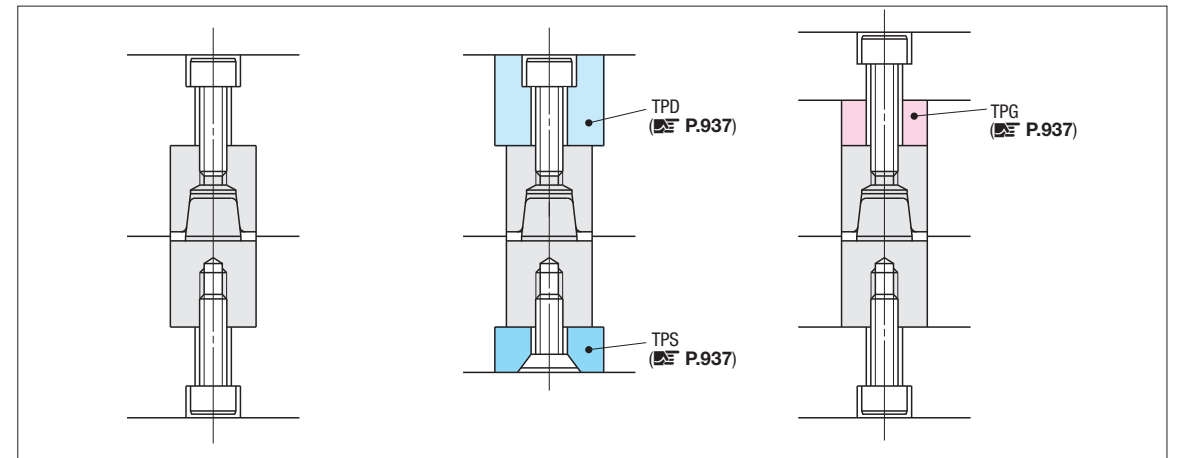

When using

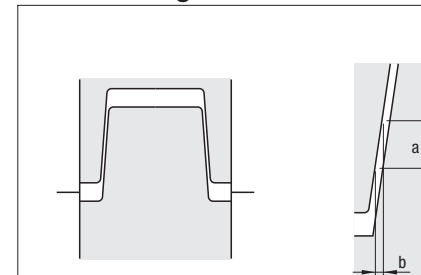

When the matching cone angle is large, the height of tapered pin and bushing must be adjusted so that they fit more tightly. On the other hand, it is necessary to take possible sticking of the pin and bushing into consideration when the angle is small. At 0.5° and 1° taper (also 3° taper in some cases), sticking can be avoided by setting them slightly afloat as shown in the figure.

When the angle is small, the creep of the height (a in the left drawing) against the width (b in the left drawings) also small so that there is no need to worry about positioning inaccuracies.

(Value b to error a) *For 0.5°, slightly afloat setting is especially recommended.

Angled	a	0.1	0.3	0.5
0.5°		0.0009	0.0026	0.0044
1°		0.0018	0.005	0.009
3°		0.005	0.016	0.026