

NEW

QUICK CHANGER

QUICK CHANGER

— ROBOT SIDE / GRIP SIDE —

Robot Side

MQCS-R-100

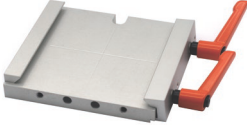

MQCS-R-160

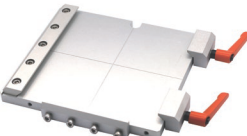

M Material	S Surface treatment
Aluminum product	Anodizing

MQCS

MQCS-R-100

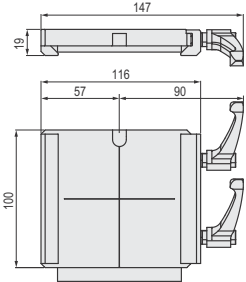

MQCS-R-160

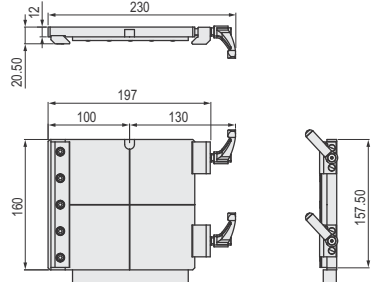

ⓘ This product is used for the purpose of quick switching and it is to be installed at Grip and robots area. Note that It may not be compatible to assemble with other products.
 ⓘ When tightening, the gap is controlled to be less than 1mm.
 ⓘ The surface is anodized, and the color of the actual product may vary from the product picture.

Part Number	Weight (g)	Compatible type	Vertical load weight (kg)*
MQCS-R-100	463	MQCS-G-100	30
MQCS-R-160	1198	MQCS-G-160	80

* Vertical load weight is the weight after combining with the supporting products.

Order

Part Number

MQCS-R-100

Days to Ship

Quotation

P

Price

Quotation

REMOVAL RELATED PRODUCTS

Grip Side

MQCS-G-100



MQCS-G-160

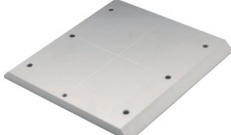

M Material	S Surface treatment
Aluminum product	Anodizing

MQCS

MQCS-G-100

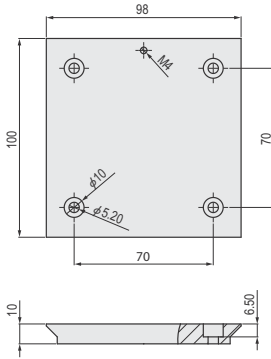

MQCS-G-160

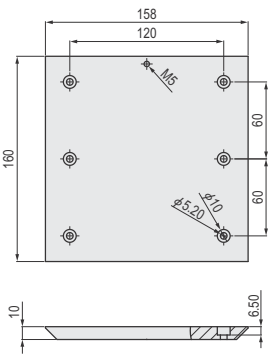

ⓘ This product is used for the purpose of quick switching and it is to be installed at Grip and robots area. Note that It may not be compatible to assemble with other products.
 ⓘ When tightening, the gap is controlled to be less than 1mm.
 ⓘ The surface is anodized, and the color of the actual product may vary from the product picture.

Part Number	Weight (g)	Compatible type
MQCS-G-100	240	MQCS-R-100
MQCS-G-160	634	MQCS-R-160

Order

Part Number

MQCS-G-100

Days to Ship

Quotation

P

Price

Quotation