

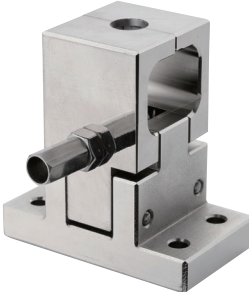

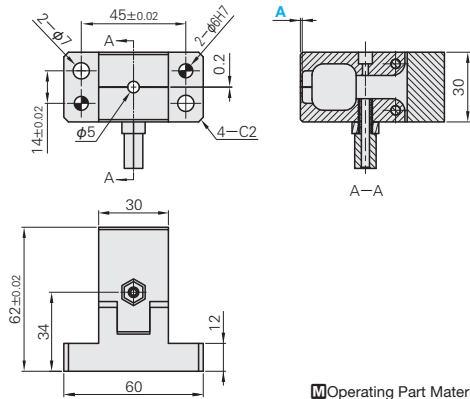







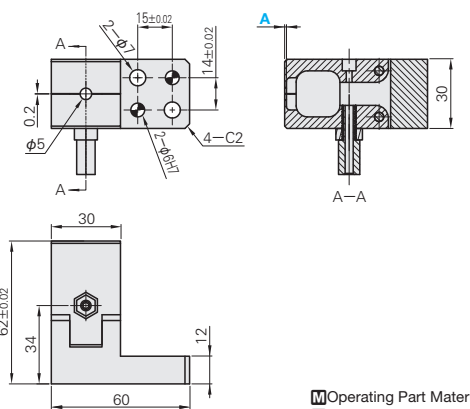

# クリップユニット CLIP UNIT

<p>Middle Type</p> 	<p><b>KKJA</b></p>  <p>  Operating Part Material SUS420J2   Surface Treatment Nickel coating         </p>
<p>Single Side Type</p> 	<p><b>KKJB</b></p>  <p>  Operating Part Material SUS420J2   Surface Treatment Nickel coating         </p>

Catalog No.	A
Type	A
<b>KKJA</b>	0.8 2.5 3.0
<b>KKJB</b>	

	Alterations	 Catalog No. — A — (N)
		<b>KKJA</b> — 2.5 — N
		<b>KKJB</b> — 0.8 — N

	Order	Catalog No. — A
		<b>KKJA</b> — 2.5 <b>KKJB</b> — 0.8
	Delivery	<b>Quotation</b>

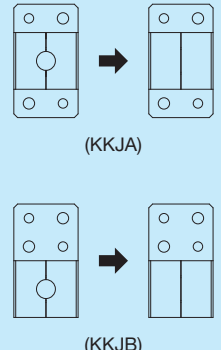
	Alterations	Code	Spec.
No hole for top surface	 <p>(KKJA)</p> <p>(KKJB)</p>	N	No hole for clamping piece of clip.

INSPECTION AND LOCATING COMPONENTS