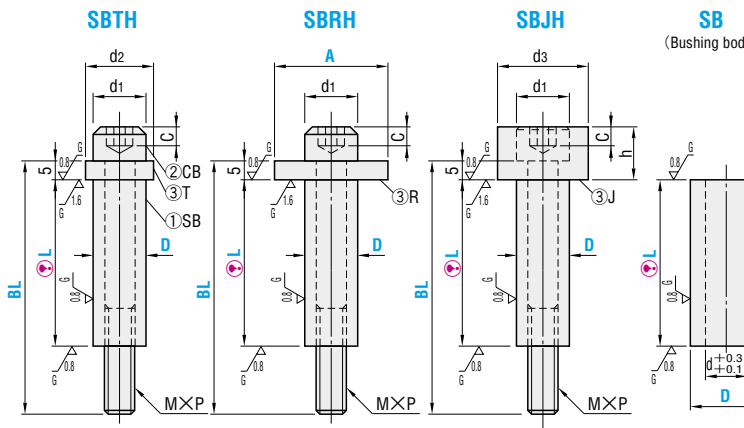

STRIPPER BOLTS, BUSHING TYPE

— HALF-MADE TYPE —

STRIPPER BOLTS, BUSHING TYPE

— THICK TYPE —

SBTH, SBRH, and SBHJ are combinations of the bushing ① + bolt ② + spacer ③.

① List of bushing type stripper bolt (half-made) combinations

Set name	Bushing body	Hexagon socket head cap screw	Spacer
(1)(2)(3)	①	②	③
SBTH	SB	CB (P.675)	T (P.815)
SBRH	SB	R (P.815)	R (P.815)
SBHJ	SB	J (P.815)	J (P.815)

If orders are placed in units of the quantity used for a single die (40 or less), they will all be ground at the same time.
 In this way, although the L dimension tolerance is ± 0.05 , the variation in the finished L dimension will be 0.01 or less.

② SCM435 (Strength class 12.9) ③ S45C 48 ~ 52HRC

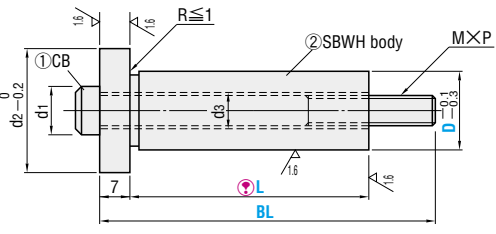
If orders are placed in units of the quantity used for a single die (40 or less), they will all be ground at the same time.
 In this way, although the L dimension tolerance is ± 0.05 , the variation in the finished L dimension will be 0.01 or less.

② SK4 53 ~ 58HRC

De _g	d ₁	SBTH d ₂	SBRH A	SBHJ h	SB d ₃	M × P	C min. depth	Catalog No. Type	D	L		BL		(SBRH only) A	Base unit price 1 ~ 19 pieces				
										0.1mm increments	5mm increments	10mm increments	SBTH		SBRH	SBHJ	SB		
6.5		7	11.5	16-18	9	12	4	SBTH SBRH SBHJ SB	6.5	10.0 ~ 70.0	20 ~ 95	—	16-18						
8	-0.025 -0.061	8.5	13	18-20-22	10	14	5		8	10.0 ~ 70.0	20 ~ 95	—	18-20-22						
10		10	15	20-22-25-27	11	18	6		10	10.0 ~ 100.0	20 ~ 95	100 ~ 170	20* - 22-25-27						
13	-0.032 -0.075	13	18	25-27-30	13	24	8		13	10.0 ~ 100.0	20 ~ 95	100 ~ 170	25* - 27-30						
16		16	21	30-35-40	15	27	10		16	10.0 ~ 100.0	20 ~ 95	100 ~ 180	30* - 35-40						
20	-0.040 -0.092	18	23	35-40	17	32	12		20	10.0 ~ 100.0	20 ~ 95	100 ~ 180	35* - 40						

The head diameter d₁ of bolts marked with * is ground so that it does not interfere with the inner diameter of the spring.

Order **Catalog No.** - **L** - **BL** - **A**

SBTH 13 - 34.5 - 50
 SBRH 10 - 27.8 - 45 - 22
 SB 13 - 34.5

Days to Ship **Quotation**

Price **Quotation**

Alterations **Catalog No.** - **L** - **BL** - **A** - (LKC-LKP)

SBRH 10 - 27.8 - 45 - 22 - LKC
 SBTH 16 - 35.85 - 90 - LKP

Alteration	Code	Spec.	1Code
L	LKC	L dimension tolerance change L ± 0.05 ⇒ L + 0.02 When LKC is used, L dimension can be selected in 0.01 mm increments.	Quotation
	LKP	L dimension tolerance change L ± 0.05 ⇒ L + 0.01 When LKP is used, L dimension can be selected in 0.01 mm increments.	

Example

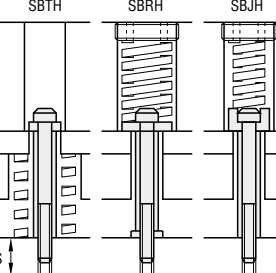

When spacer is used

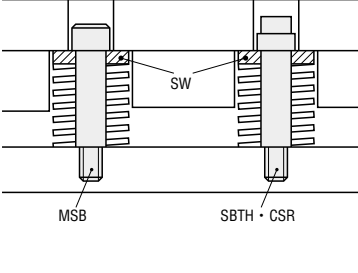

BL < S + L + 5

d ₁	d ₂	d ₃	M × P	Catalog No.		L 0.1mm increments	BL 5mm increments	Base unit price 1 ~ 19 pieces
				Type	D			
8.5	21	5.5	5 × 0.8	SBWH	13	15.0 ~ 65.0	30 ~ 80	Quotation
10	25	6.5	6 × 1.0		16	15.0 ~ 65.0	30 ~ 90	
13	30	8.5	8 × 1.25		20	20.0 ~ 70.0	35 ~ 90-100	

Order **Catalog No.** - **L** - **BL**

SBWH 13 - 30.0 - 50

Price **Quotation**

Days to Ship **Quotation**

Spacers and washers for bushing-type stripper bolts



T-R (Spacers for bushing-type stripper bolts)

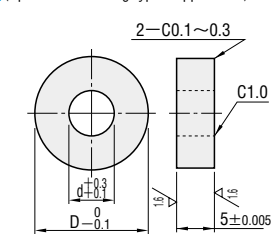

S45C 48 ~ 52HRC



J (Spacers with counterbore for bushing-type stripper bolts)

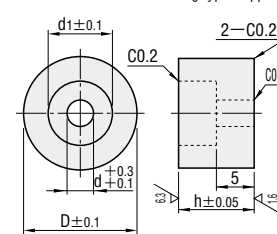

S45C 48 ~ 52HRC



SW (Coil spring washers for bushing-type stripper bolts)

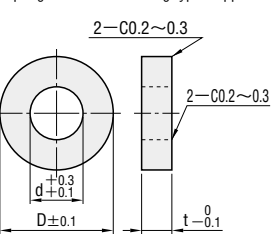

S45C 48 ~ 52HRC

D	d	Catalog No.	Base unit price	Volume discount unit price
			1 ~ 49 pieces	50 ~ 199 / 200 ~ 499 / 500 ~ 1000
11.5	4	T	6.5	
13	5		8	
15	6		10	
18	8		13	
21	10		16	
23	12		20	
16	4	R	6.5-16	
18	4		6.5-18	
18	5		8-18	
20	5		8-20	
22	5		8-22	
20	6		10-20	
22	6		10-22	
25	6		10-25	
27	6		10-27	
25	8		13-25	
27	8		13-27	
30	8		13-30	
30	10	16-30		
35	10	16-35		
40	10	16-40		
35	12	20-35		
40	12	20-40		

D	d ₁	d ₂	h	Catalog No.	Base unit price	Volume discount unit price
					1 ~ 49 pieces	50 ~ 199 / 200 ~ 499 / 500 ~ 1000
12	8	4	9	J	6.5	
14	10	5	10		8	
18	11	6	11		10	
24	14	8	13		13	Quotation
27	17.5	10	15		16	
32	19.5	12	17		20	

D	d	t	Catalog No.	Base unit price	Volume discount unit price
				1 ~ 49 pieces	20 ~ 49 / 50 ~ 99 / 100 ~ 200
10	4.5	3	10		
12	5.5		12		
16	6.5		12-6		
20	8		16		
22	8		20		
25	10		22		
12	5	5	25		
12	5		25-12		
27	13		27		
30	13		30		
35	16		35		
40	16		40		
50	20	10	50		
			50		

Order **Catalog No.**

SW 25

Days to Ship **Quotation**