

NAAMS STANDARD FLYING CAM UNITS

—MGFNS • MEFNS—



MGFNS80 MEFNS80

(Economy type)

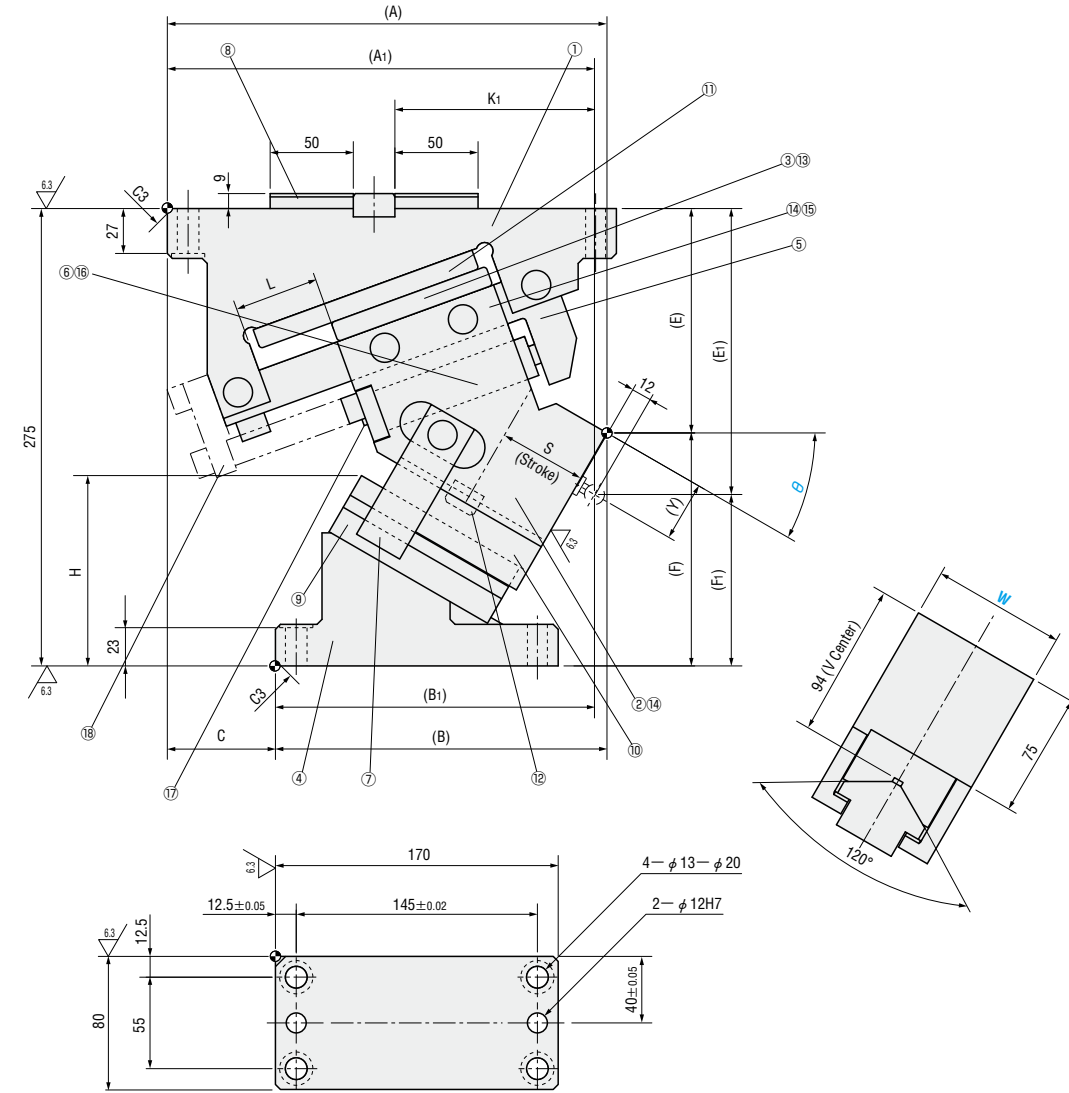
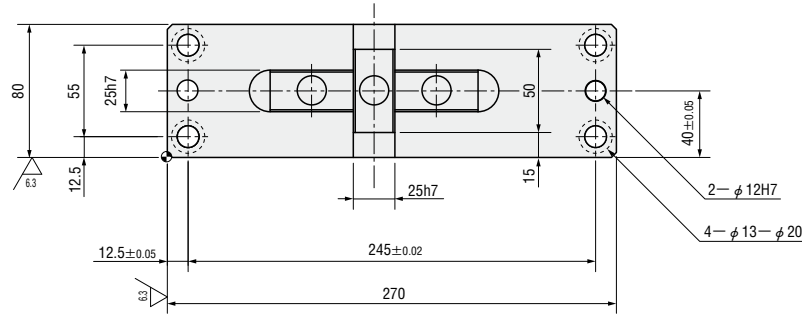

Components table P.1311

W	θ	A	A ₁	B	B ₁	C	E	E ₁	F	F ₁	H	L	K ₁	Y
80	00	280	292	145	157	135	110	155	165	120	69	50	180	45
	05	281.31	289.5	156.31	164.5	125	115.93	160	159.07	115	73.5		160.5	43.19
	10	277.5	281.37	167.5	171.37	110	117.84	165	157.16	110	82.6		153	45.77
	15	280.48	279.7	175.48	174.7	105	120.72	170	154.28	105	91.3		144	47.8
	20	276.16	270.57	181.16	175.57	95	124.55	175	150.45	100	99.6		136.5	49.32
	25	271.47	261.07	191.47	181.07	80	129.29	180	145.71	95	107.3		127.5	50.35
	30	264.33	249.27	199.33	184.27	65	134.92	185	140.08	90	114.5		120	50.9
	35	260.66	241.26	205.66	186.26	55	141.38	190	133.62	85	120.9		112.5	50.95
	40	252.32	228.34	217.32	193.34	35	147.76	195	127.24	80	126.8		105	51.6
	45	247.46	221.04	217.46	191.04	30	156.61	200	118.39	75	131.8		99	49.36
	50	237.8	209.12	222.8	194.12	15	165.27	205	109.73	70	136.1		93	47.51
	55	231.36	201.62	231.36	201.62	0	174.53	210	100.47	65	139.6		72	44.7
60	233.95	207.53	233.95	207.53		185.89	215	89.11	60	140.7	40	79	37.43	

Slide Stroke S	Working force KN (tonf)	Total weight kg	Catalog No.	W	θ	Spring Code
32.1	166.7 (17.0)	27.9	MGFNS MEFNS (Economy type)	80	00	GK ISO NGK NISO
35.5		27.5			05	
38.9		26.9			10	
42.4		26.5			15	
46.1		26.0			20	
50.0		25.9			25	
54.3		25.3			30	
59.0		25.0			35	
64.3		24.7			40	
70.4		24.7			45	
77.8		24.9			50	
78.5		25.8			55	
80.0	26.2	60				

Spring type

Spring Code	Spring specification	Spring load N (kgf)				Remarks
		θ	Preload	5mm before bottom dead center	Max. load	
GK	M150—50	—	—	—	2350(240.0)	Gas spring (Equivalent to KALLER)
ISO	φ 32×152	00	74 (7.5)	1044(106.5)	1224(124.8)	Coil spring (Constant=23.0N/mm)
		05		1063(108.4)		
		10		1076(109.8)		
		15		1088(110.9)		
		20		1099(112.1)		
		25		1109(113.0)		
		30		1118(114.0)		
		35		1127(114.9)		
		40		1134(115.6)		
		45		1143(116.6)		
		50		1150(117.3)		
55	1042(106.2)	1109(113.0)				
60	936(95.5)	994(101.3)				
NGK	—	—	—	—	—	Without gas spring
NISO	—	—	—	—	—	Without coil spring



Order Catalog No. **MGFNS** W **80** - θ **30** - Spring Code **ISO**



Days to Ship **Quotation**



Price **Quotation**



Alterations Catalog No. **MGFNS** W **80** - θ **05** - Spring Code **GK** - (NF)

Alteration	Code	Spec.
	NF	No nitrogen is filled into gas spring. Only for GK.